

# Goldfish 4

*Production year 2008*

*Production année 2008*

## **PARTS CATALOGUE**

## **CATALOGUE DE PIÈCES DÉTACHÉES**

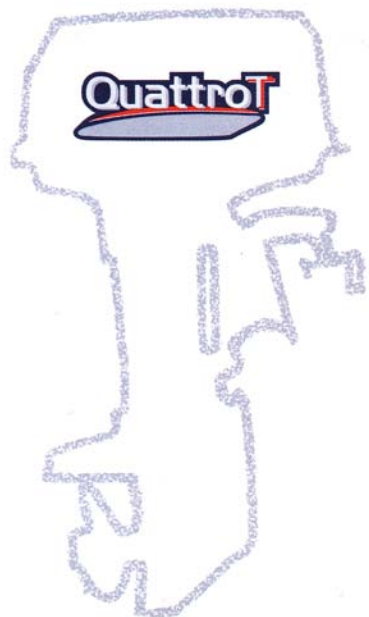

ENGINE STARTING SERIAL NUMBER: S/L 1069180



A1

# FOREWORD

This Parts Catalogue is related to the parts for the model(s) on the cover page. When you are ordering replacement parts, please refer to this Parts Catalogue and quote both part numbers and part names correctly.

1. Modifications or additions which have been made after the issue of the Parts Catalogue will be announced in the Parts News.  
It is advisable that you make the necessary corrections to the Parts Catalogue according to the Parts News.

2. Abbreviations

The following abbreviations are used in this Parts Catalogue.

“UR” Use specified parts number.

“UN” Use as many as needed.

“AP” Alternate Parts

“LM” Locally Made (Parts need to be ordered locally)

“F#” Frame No. (Applicable machine No.)

“O/S” Over Size

3. The number of components for assembly

- Parts, which are to be supplied in an assembly, are listed with a dot (.) in front of the part name as shown below.
- The numeral appearing to the right of each component part indicates the quantity of parts for each assembly unit.

PART NO.	DESCRIPTION	Q'TY	REMARKS
2F5-83310-60	FRONT FLASHER LIGHT ASSY	2	
115-83311-60	.BULB (6V-18W)	1	

4. Applicable colours of graphics are represented in the “REMARKS” as shown below.

PART NO.	DESCRIPTION	Q'TY	REMARKS
2N4-24110-00-X5	FUEL TANK COMP.	2	MXR
3J1-24240-10	.GRAPHIC, FUEL TANK	1	FOR MXR

5. Note that the illustrations for reference in finding parts numbers are not to be used for assembling. When assembling, please use the applicable service manual.

6. The asterisk (\*) before a reference number indicates modified items after the first edition.

7. Applicable Serial No.

Engine Serial No.

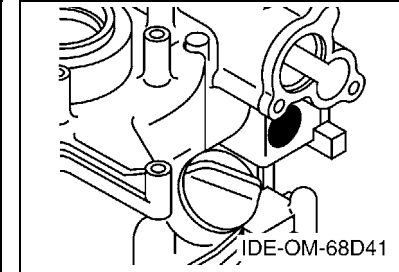
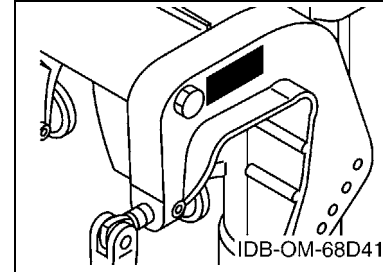

8. Applicable Engine Starting Serial No.

Model	Serial No.	Model	Serial No.
Goldfish 4	68D-1069180		

9. Applicable Colour Code

Abbreviation	Colour Name	Colour Code
DBNM2	DARK BLUISH GRAY METALLIC 2	004D

10. Quantity Column Information

Column No.	Name Of Q'ty Column	Applicable Model
1	68D8	F4AMH

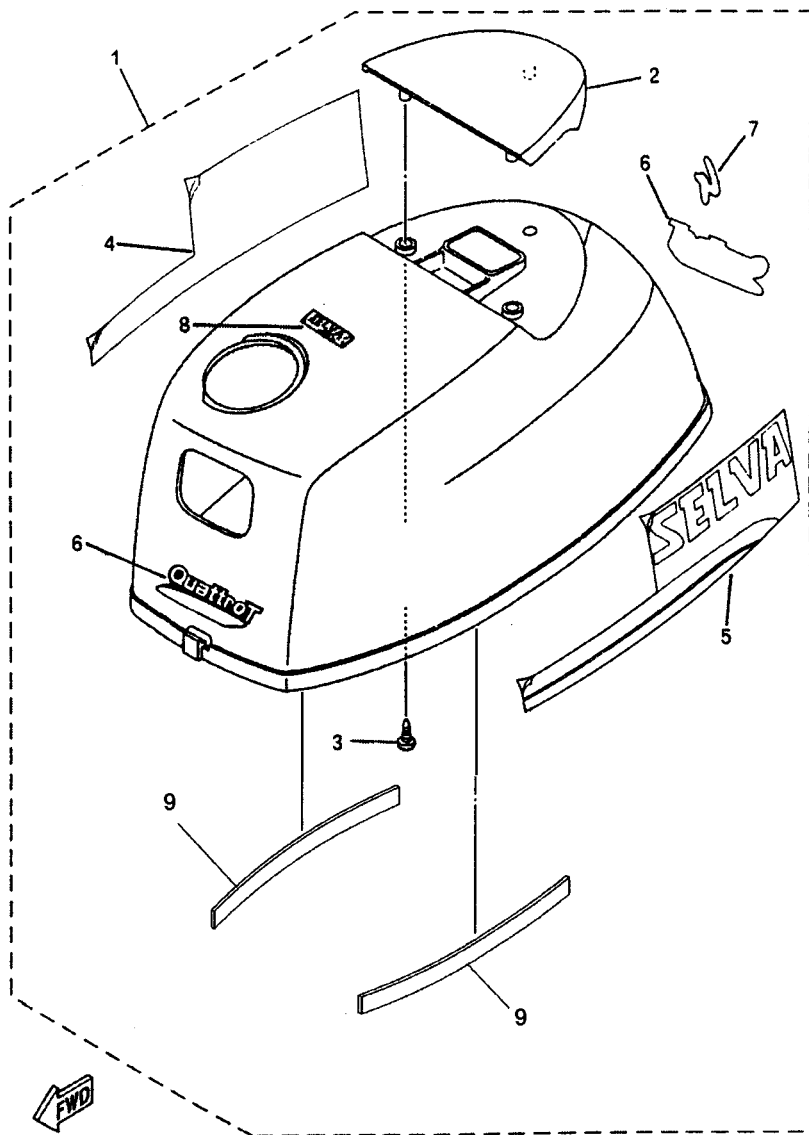
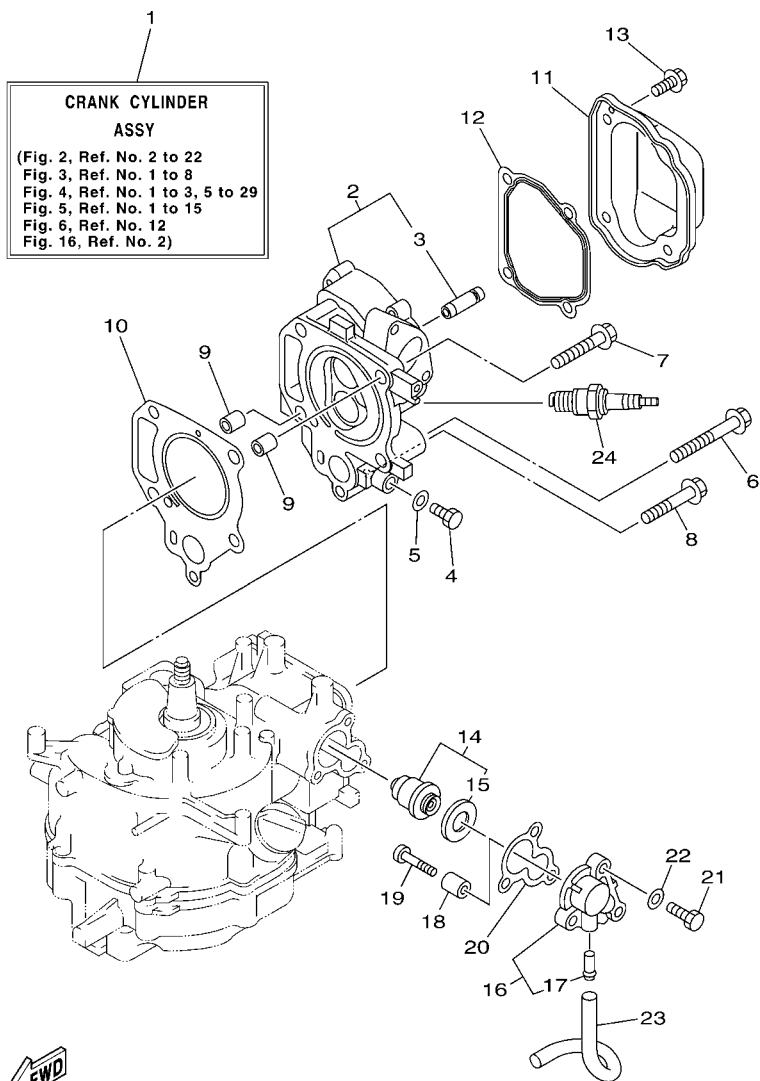

FIG. 1 TOP COWLING

CAPOT SUPERIEUR

REF. NO.	PART NO. NO. PIECES	DESCRIPTION DESCRIPTION	4SI				REMARKS REMARQUES
1	1504060	TOP COWLING ASSY CAPOT (ENS.)	1				
2	68D-G2613-01	.MOLDING, AIR DUCT .MANCHON A AIR	1				
3	97780-40012	.SCREW, TAPPING .VIS, TETE FRAISEE	3				
4	8092660	.GRAPHIC, RIGHT .ADHESIF, DROIT	1				
5	8092662	.GRAPHIC, LEFT .ADHESIF, GOUCHE	1				
6	8092684	.GRAPHIC, 4T .ADHESIF, 4T	2				
7	8091851	.GRAPHIC, 4 .ADHESIF, 4	1				
8	8092605	.GRAPHIC, SELVA MARINE .ADHESIF, SELVA MARINE	1				
9	68D-42662-00	.DAMPER .AMORTISSEUR	2				
	1533965	.GRAPHIC, SET .ADHESIF, CAPOT	1				



**FWD**  
 68D6300-E020

**FIG. 2 CYLINDER & CRANKCASE 1 CYLINDRE & CARTER 1**

REF. NO.	PART NO. N° PIECES	DESCRIPTION DESCRIPTION	4	5	6	7	8	REMARKS REMARQUES
1	68D-WE090-11-1S	CRANK CYLINDER ASSY EMBIELLAGE CYLINDRE (ENS.)	1					
2	68D-E1111-10-1S	HEAD, CYLINDER 1 CULASSE	1					
3	67D-11133-10	.GUIDE, VALVE 1 .GUIDE, SOUPAPE 1	2					
4	97095-08014	BOLT BOULON	1					
5	90430-08800	GASKET JOINT	1					
6	90105-08M36	BOLT, FLANGE BOULON	3					
7	90105-08046	BOLT, FLANGE BOULON	1					
8	90105-06056	BOLT, FLANGE BOULON	1					
9	99510-10114	PIN, DOWEL GOUJON, D'ASSEMBLAGE	2					
10	67D-11181-A0	GASKET, CYLINDER HEAD 1 JOINT, DE CULASSE 1	1					
11	67D-11191-00	COVER, CYLINDER HEAD 1 COUVERCLE, CULASSE 1	1					
12	68D-E1193-A0	GASKET, HEAD COVER 1 JOINT, COUVERCLE DE CULASSE 1	1					
13	90105-06039	BOLT, FLANGE BOULON	4					
14	66M-12411-01	THERMOSTAT THERMOSTAT	1					
15	688-12412-00	.SEAL, THERMOSTAT .JOINT, THERMOSTAT	1					
16	68D-E2413-00-1S	COVER, THERMOSTAT COUVERCLE, THERMOSTAT	1					
17	650-24378-00	.PIPE, JOINT 4 .DURITE RACCORDEMENT 3	1					
18	68D-E1325-00	ANODE ANODE	1					
19	97880-05025	SCREW, PAN HEAD VIS, TETE TRONCONIQUE	1					
20	68D-E2414-A0	GASKET, COVER JOINT, COUVERCLE	1					
21	97095-06020	BOLT BOULON	3					
22	92995-06600	WASHER RONDELLE	3					
23	90445-09807	HOSE (L180) DURITE (L180)	1					
24	94702-00248	PLUG, SPARK (NGK BR6HS) BOUGIE D,ALLUMAGE (NGK BR6HS)	1					

FIG. 3 CRANKSHAFT & PISTON

VILEBREQUIN & PISTON

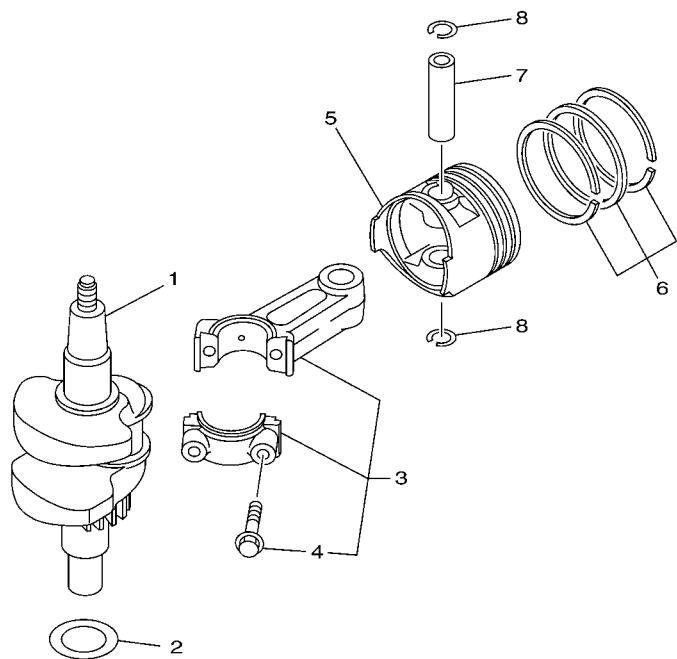

REF. NO.	PART NO. N° PIECES	DESCRIPTION DESCRIPTION	4	5	6	7	8	REMARKS REMARQUES
1	67D-11400-00	CRANKSHAFT ASSY VILEBREQUIN COMPLET	1					
2	90201-266P2	WASHER, PLATE RONDELLE, PLATE	1					
3	67D-11650-00	CONNECTING ROD ASSY BIELLE COMPLETE	1					
4	67D-11654-00	.BOLT, CONNECTING ROD .BOULON, BIELLE	2					
5	68D-E1631-00-96	PISTON (STD) PISTON (STD)	1					
	68D-E1635-00	PISTON (0.25MM O/S) PISTON (0.25MM O/S)	1					AP AP
	68D-E1636-00	PISTON (0.50MM O/S) PISTON (0.50MM O/S)	1					AP AP
6	68D-E1603-00	PISTON RING SET (STD) JEU DE SEGMENTS (STD)	1					
	68D-E1604-00	PISTON RING SET (0.25MM O/S) JEU DE SEGMENTS (0.25MM O/S)	1					AP AP
	68D-E1605-00	PISTON RING SET (0.50MM O/S) JEU DE SEGMENTS (0.50MM O/S)	1					AP AP
7	68D-E1633-00	PIN, PISTON AXE, PISTON	1					
8	93450-14088	CIRCLIP CIRCLIP, TYPE S	2					



67D0010-8030

FIG. 4 CYLINDER & CRANKCASE 2 CYLINDRE & CARTER 2

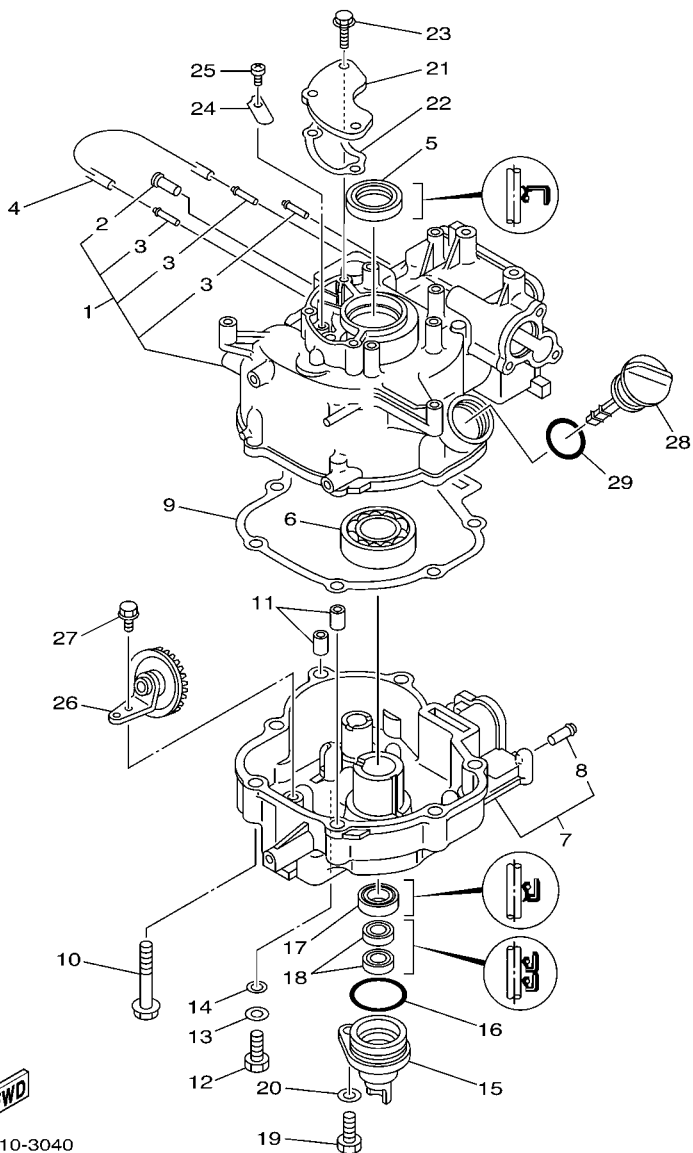

68D3010-3040

REF. NO.	PART NO. N° PIECES	DESCRIPTION DESCRIPTION	QTY				REMARKS REMARQUES
1	68D-E1311-02-1S	CYLINDER 1 CYLINDRE 1	1				
2	650-24378-00	.PIPE, JOINT 4 .DURITE RACCORDEMENT 3	1				
3	6H1-14485-00	.PIPE, JOINT .DURITE	3				
4	90445-07806	HOSE (L167) DURITE (L167)	1				
5	93102-25090	OIL SEAL JOINT SPY	1				
6	93306-205YD	BEARING ROULEMENT	1				
7	68D-E5111-00-1S	CRANKCASE 1 CARTER DE MOTEUR	1				
8	650-24378-00	.PIPE, JOINT 4 .DURITE RACCORDEMENT 3	1				
9	68D-11351-A0	GASKET, CYLINDER JOINT, D'EMBASE	1				
10	97575-08550	BOLT, WITH WASHER VIS HEXAGONAL AVEC RONDELLE	7				
11	99510-10114	PIN, DOWEL GOUJON, D'ASSEMBLAGE	2				
12	97095-08020	BOLT BOULON	1				
13	92995-08600	WASHER RONDELLE	1				
14	90201-08818	WASHER, PLATE RONDELLE, PLATE	1				
15	68D-E5396-00-5B	HOUSING, OIL SEAL LOGEMENT DE JOINT SPY	1				
16	93210-35537	O-RING JOINT TORIQUE	1				
17	93102-20108	OIL SEAL JOINT SPY	1				
18	93102-10004	OIL SEAL JOINT SPY	2				
19	97095-08020	BOLT BOULON	1				
20	92995-08600	WASHER RONDELLE	1				
21	68D-E1168-00	COVER, BREATHER COUVERCLE, RENIFLARD	1				
22	68D-E1169-A0	GASKET, BREATHER COVER JOINT, COUVERCLE DE RENIFLARD	1				
23	90119-06M80	BOLT, WITH WASHER BOULON, AVEC RONDELLE	3				
24	68D-E5346-00	BREATHER 1 RENIFLARD 1	1				
25	98503-04006	SCREW, PAN HEAD VIS	1				
26	68D-E3102-00	GEAR UNIT ASSY PIGNON	1				
27	95817-06012	BOLT, FLANGE BOULON, A COLLERETTE	1				

FIG. 4 CYLINDER & CRANKCASE 2

CYLINDRE & CARTER 2

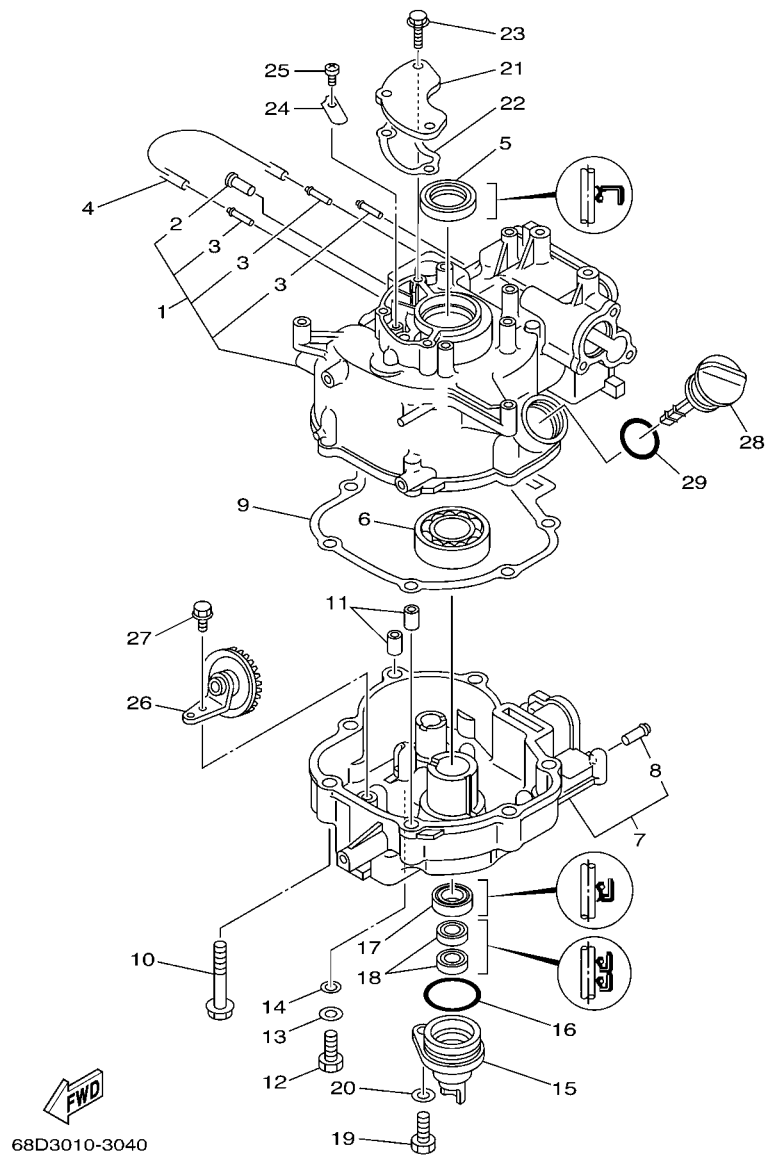

REF. NO.	PART NO. N° PIECES	DESCRIPTION DESCRIPTION	4	5	REMARKS REMARQUES
28	68D-E5362-00	PLUG, OIL LEVEL PLOT, NIVEAU D'HUILE	1		
29	93210-24M79	O-RING JOINT TORIQUE	1		

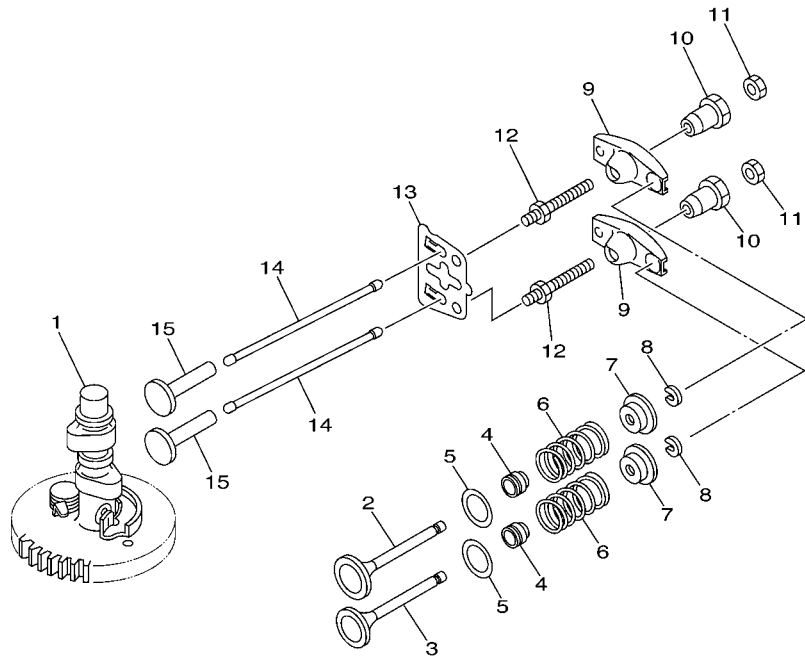

FIG. 5 VALVE

SOUPAPE

REF. NO.	PART NO. N° PIECES	DESCRIPTION DESCRIPTION	4 5				REMARKS REMARQUES
1	68D-E2170-00	CAMSHAFT ASSY 1 ENS ARBRE A CAMES 1	1				
2	67D-12111-00	VALVE, INTAKE SOUPAPE, ADMISSION	1				
3	67D-12121-00	VALVE, EXHAUST SOUPAPE, ECHAPPEMENT	1				
4	51Y-12119-00	SEAL, VALVE STEM JOINT, QUEUE DE SOUPAPE	2				
5	68T-12116-00	SEAT, VALVE SPRING SIEGE, RESSORT DE SOUPAPE	2				
6	68D-E2113-00	SPRING, VALVE INNER RESSORT DE SOUPAPE, INTERNE	2				
7	7NJ-12117-00	RETAINER, VALVE SPRING BUTEE DE RESSORT DE SOUPAPE	2				
8	7NJ-12118-00	COTTER, VALVE FRAISE, SOUPAPE	2				
9	67D-12151-00	ARM, VALVE ROCKER CULBUTEUR	2				
10	7FK-12165-00	PIVOT, ROCKER ARM PIVOT, CULBUTEUR	2				
11	7FK-12158-00	NUT, LOCK CONTRE-ECROU	2				
12	67D-12157-00	BOLT BOULON	2				
13	68D-E2155-00	GUIDE, PUSH ROD GUIDE, TIGE-POUSSOIR	1				
14	67D-12154-00	ROD, VALVE PUSH TIGE DE LEVE-SOUPAPE	2				
15	JA9-12153-00	LIFTER, VALVE LEVE-SOUPAPE	2				



68D3010-3050



ADMISSION

FIG. 6 INTAKE

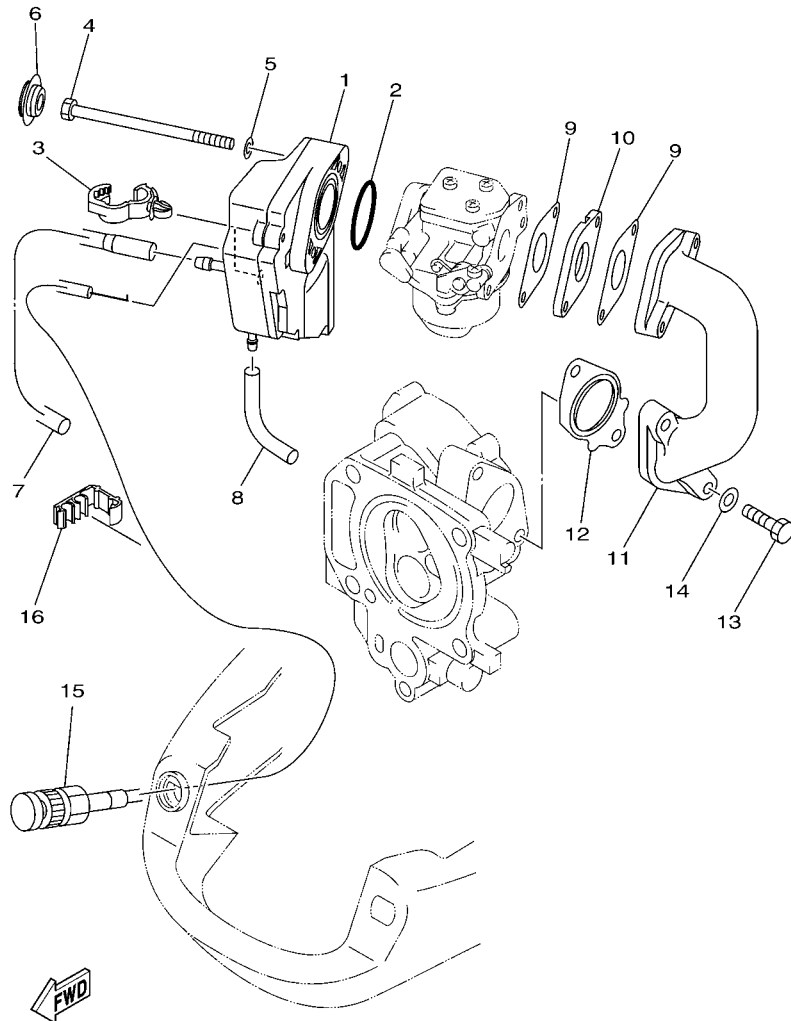

67D0010-8060

REF. NO.	PART NO. N° PIECES	DESCRIPTION DESCRIPTION	4	5	6	7	8	REMARKS REMARQUES
1	68D-E4440-00	SILENCER ASSY, INTAKE SIENCIEUX D'ADMISSION	1					
2	93210-31MJ5	O-RING JOINT TORIQUE	1					
3	90464-13249	CLAMP BRIDE	1					
4	97095-06090	BOLT BOULON	2					
5	92995-06600	WASHER RONDELLE	2					
6	90480-18M74	GROMMET PASSE-FIL	2					
7	68D-F4314-00	PIPE 4 DURITE 4	1					
8	90445-07805	HOSE (L70) DURITE (L70)	1					
9	68D-E3646-A0	GASKET, MANIFOLD 2 JOINT, TUBULURE 2	2					
10	68D-E3647-00	GASKET, MANIFOLD 3 JOINT, TUBULURE 3	1					
11	68D-E3641-00-94	MANIFOLD 1 TUBULURE 1	1					
12	68D-E3645-A0	GASKET, MANIFOLD 1 JOINT, TUBULURE 1	1					
13	97095-06025	BOLT BOULON	2					
14	92995-06600	WASHER RONDELLE	2					
15	68D-F6330-00	STARTER CABLE ASSY CABLE DE STARTER	1					
16	90464-05122	CLAMP BRIDE	1					

FIG. 7 CARBURETOR

CARBURATEUR

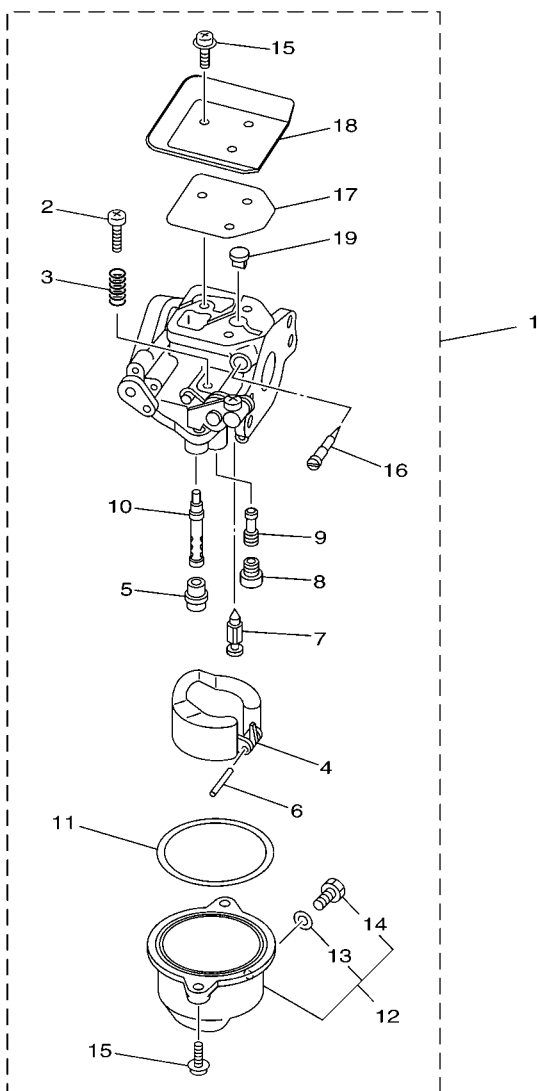

REF. NO.	PART NO. N° PIECES	DESCRIPTION DESCRIPTION	4 5				REMARKS REMARQUES
1	67D-14301-22	CARBURETOR ASSY 1 CARBURATEUR COMPLET 1	1				
2	6E5-14321-00	.SCREW, THROTTLE .VIS, ACCELERATEUR	1				
3	6J8-14334-00	.SPRING, THROTTLE .RESSORT, ACCELERATEUR	1				
4	68T-14385-00	.FLOAT .FLOTTEUR	1				
5	67D-14966-00	.RUBBER CAP .CAOUTCHOUC CASQUILLO	1				
6	67D-14386-00	.PIN, FLOAT .AXE, FLOTTEUR	1				
7	67D-14546-00	.VALVE, NEEDLE .POINTEAU	1				
8	67D-1492E-34	.JET, MAIN (#68) .GICLEUR, PRINCIPAL (#68)	1				
9	67D-1492F-18	.JET, AIR SLOW (#36) .GICLEUR, AIR (#36)	1				
10	67D-1492A-00	.NOZZLE, MAIN .PUIIS D'AIGUILLE	1				
11	67D-14984-00	.GASKET, FLOAT CHAMBER .JOINT, CUVE DE FLOTTEUR	1				
12	67D-14981-00	.BODY, FLOAT CHAMBER .CORPS, CUVE DE FLOTTEUR	1				
13	6J8-14959-00	..GASKET ..JOINT	1				
14	66T-14991-00	..PLUG, DRAIN ..BOUCHON DE VIDANGE	1				
15	97980-04112	.SCREW, WITH WASHER .VIS, AVEC RONDELLE	5				
16	68T-14323-20	.SCREW, AIR ADJUSTING .VIS DE DOSEUR D'AIR	1				
17	67D-14536-00	.GASKET .JOINT	1				
18	67D-14527-01	.PLATE .PLAQUE	1				
19	67D-14126-00	.PLUG .PLOT	1				

FWD  
68D5010-D070

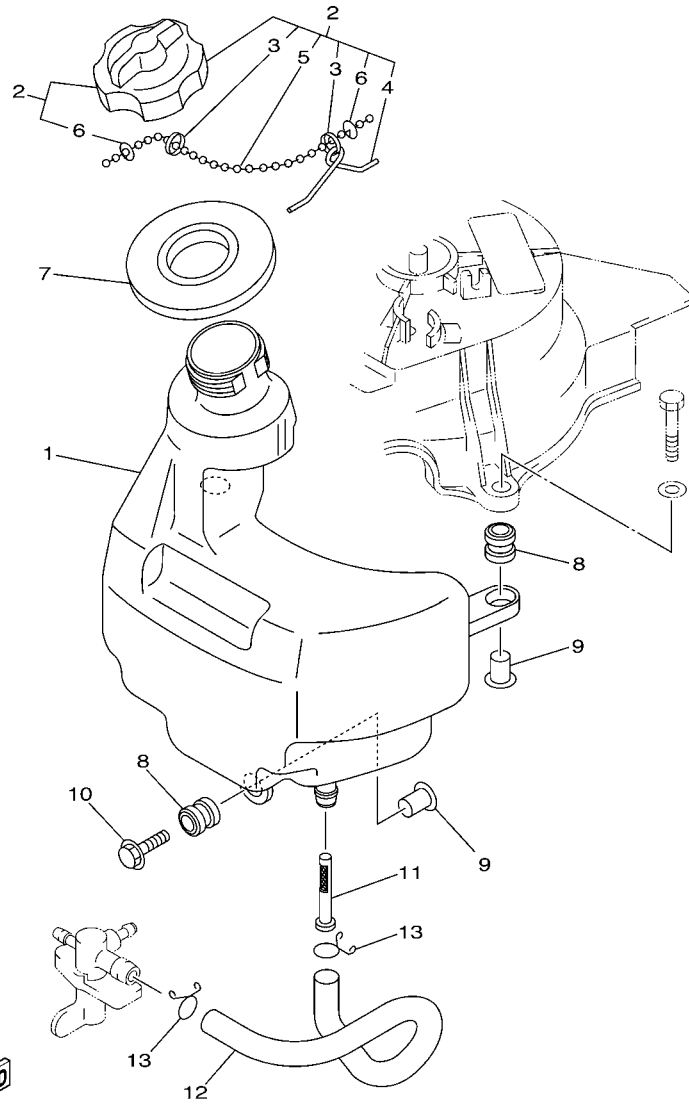

68D3010-3080



FIG. 8 FUEL 1

CARBURANT 1

REF. NO.	PART NO. N° PIECES	DESCRIPTION DESCRIPTION	4 5				REMARKS REMARQUES
1	68D-F4111-00	TANK, FUEL RESERVOIR, A ESSENCE	1				
2	67D-24610-03	CAP ASSY BOUCHON	1				
3	90501-10260	.SPRING, COMPRESSION .RESSORT, COMPRESSION	2				
4	624-24634-00	.HOOK, CHAIN BALL .ATTACHE	1				
5	69M-24633-00	.CHAIN, BALL .CHANE DE BALLE	1				
6	67D-21757-00	.WASHER, SPECIAL 1 .RONDELLE, SPECIALE 1	2				
7	6L5-24641-00	GASKET, CAP 1 JOINT 1, BOUCHON	1				
8	6A0-82317-00	DAMPER, IGNITION COIL AMORTISSEUR, BOBINE D'ALLUM	3				
9	90387-06119	COLLAR COLLERETTE	3				
10	90119-06M88	BOLT, WITH WASHER BOULON, AVEC RONDELLE	1				
11	6L5-24251-00	STRAINER 1 FILTRE 1	1				
12	68D-F4311-00	PIPE, FUEL 1 DURITE A ESSENCE	1				
13	90467-13M13	CLIP JONC	2				

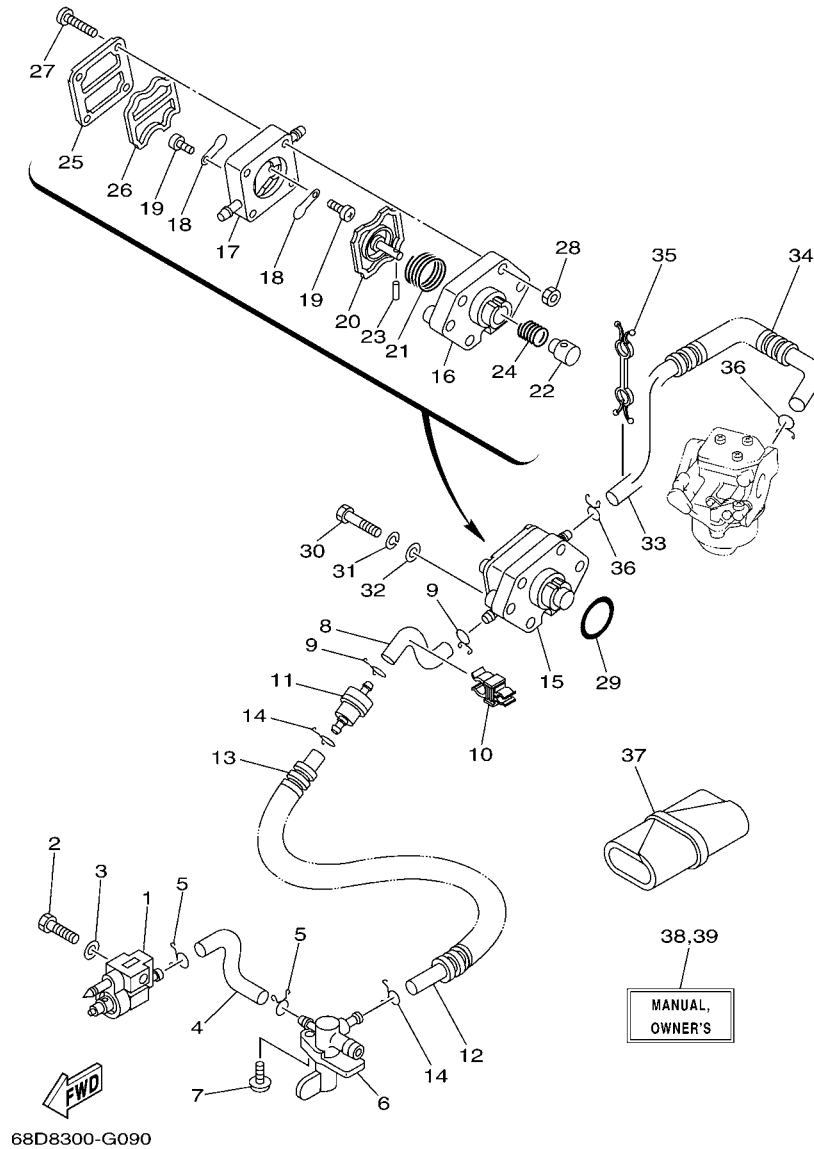

FIG. 9 FUEL 2

CARBURANT 2

REF. NO.	PART NO. N° PIECES	DESCRIPTION DESCRIPTION	4 5				REMARKS REMARQUES
1	6G1-24304-02	FUEL PIPE JOINT COMP. 1 DURITE RACCORDEMT. A ESSENCE	1				
2	97095-06025	BOLT BOULON	1				
3	92995-06600	WASHER RONDELLE	1				
4	68D-F4312-00	PIPE 2 DURITE 2	1				
5	90467-09M09	CLIP JONC	2				
6	67D-24500-00	FUEL COCK ASSY 1 ROBINET A ESSENCE	1				
7	90159-06M10	SCREW, WITH WASHER VIS, AVEC RONDELLE	1				
8	68D-F4313-00	PIPE 3 DURITE 3	1				
9	90467-09M09	CLIP JONC	2				
10	90464-10M52	CLAMP BRIDE	1				
11	646-24251-02	STRAINER 1 FILTRE 1	1				
12	90445-10804	HOSE (L140) DURITE (L140)	1				
13	90446-14M12	HOSE DURITE	1				
14	90467-09M09	CLIP JONC	2				
15	67D-24410-03	FUEL PUMP ASSY POMPE A ESSENCE	1				
16	67D-24412-00	.BODY 1	1				
17	67D-24413-02	.BODY 2 .CORPS 2	1				
18	6A0-24421-01	.VALVE, CHECK .SOUPAPE, RETENUE	2				
19	6E7-14325-00	.SCREW, PAN HEAD .VIS TETE CONIQUE	2				
20	67D-24411-01	.DIAPHRAGM .DIAPHRAGME	1				
21	67D-24423-00	.SPRING, DIAPHRAGM .RESSORT, DIAPHRAGME	1				
22	67D-13131-00	.PLUNGER .PLONGEUR	1				
23	66M-24374-00	.PIN .GOUILLE	1				
24	67D-24454-00	.SPRING .RESSORT	1				
25	67D-24414-01	.BODY 3 .CORPS 3	1				
26	66M-24471-01	.DIAPHRAGM .DIAPHRAGME	1				
27	67D-24444-00	.SCREW .VIS	4				

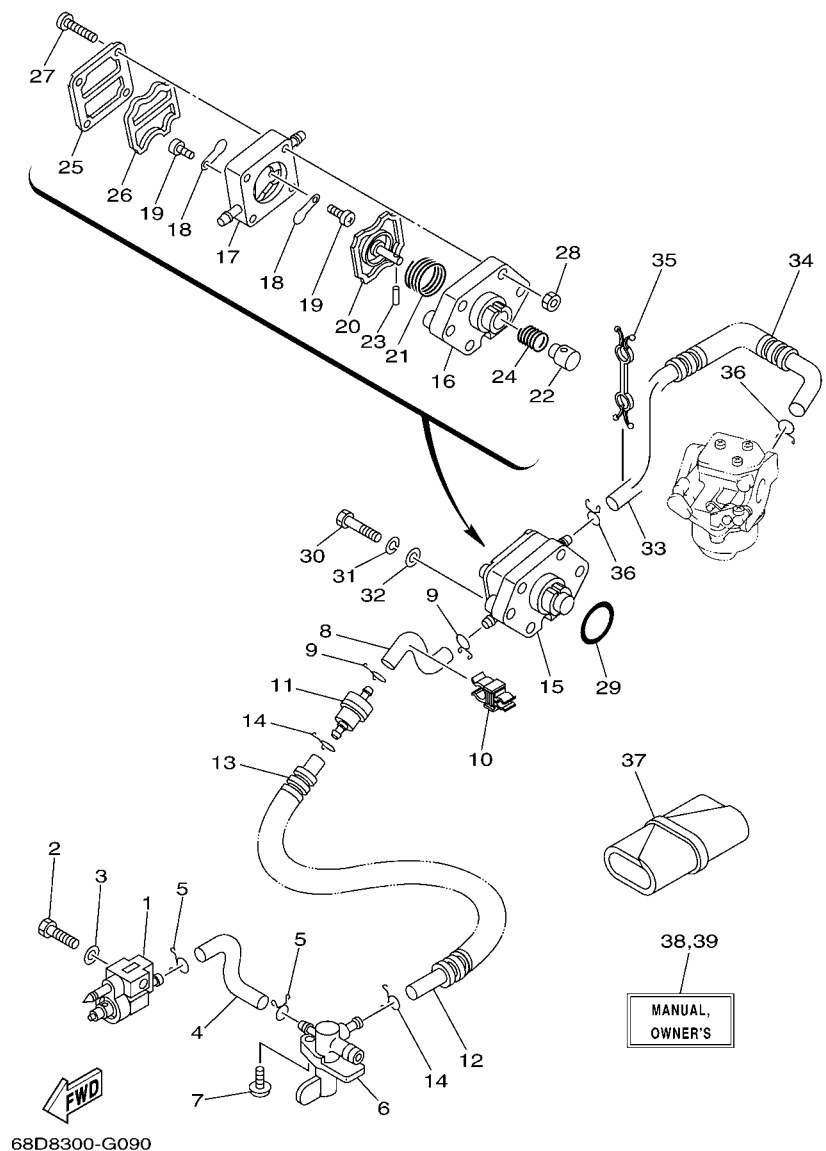

FIG. 9 FUEL 2

CARBURANT 2

REF. NO.	PART NO. N° PIECES	DESCRIPTION DESCRIPTION	4 5			REMARKS REMARQUES
28	95380-04600	.NUT .ECROU	4			
29	93210-27ME3	O-RING JOINT TORIQUE	1			
30	97095-06030	BOLT BOULON	2			
31	92995-06100	WASHER, SPRING RONDELLE, GROWER	2			
32	92995-06600	WASHER RONDELLE	2			
33	90445-10805	HOSE (L250) DURITE (L250)	1			
34	90446-14M12	HOSE DURITE	1			
35	90464-10M53	CLAMP BRIDE	1			
36	90467-09M09	CLIP JONC	2			
37	68D-F8100-00	TOOL KIT TROUSSE A OUTILS	1			

FIG. 10 STARTER

DEMARREUR

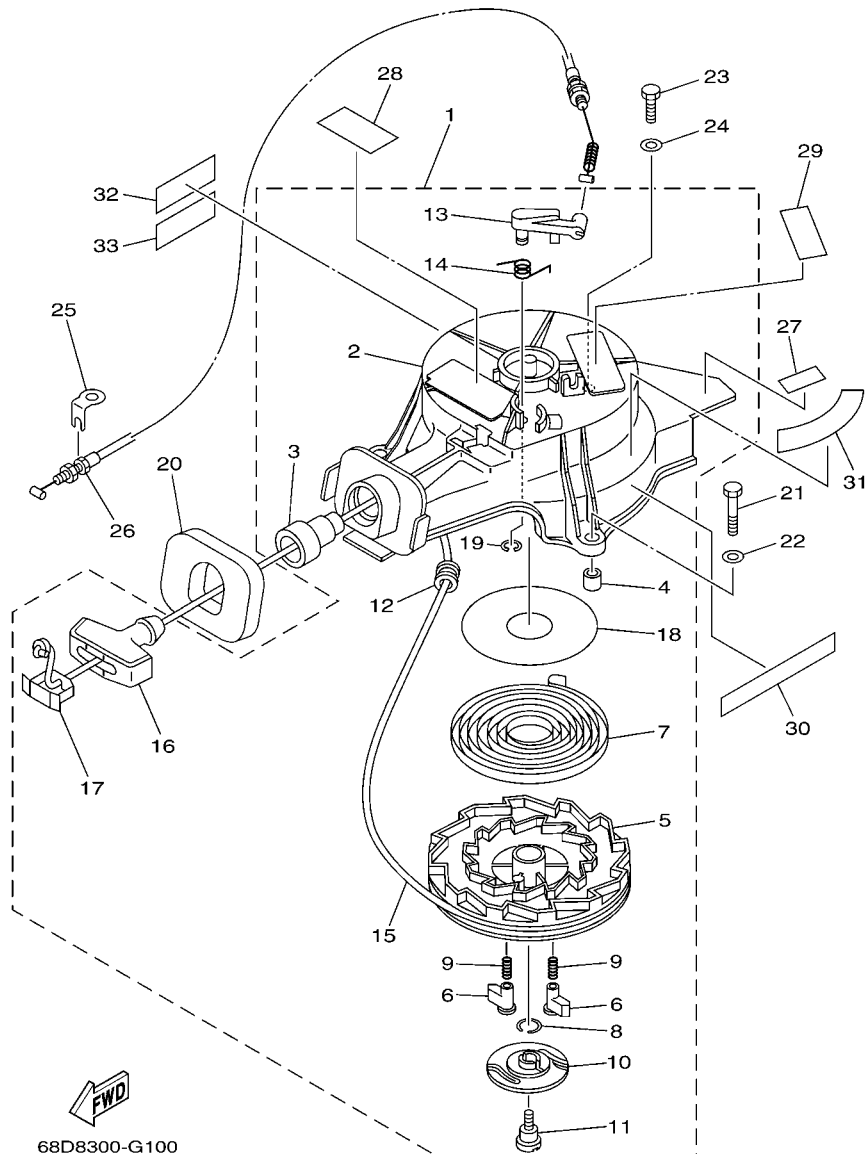

68D8300-G100

\*1: CUT FROM 50M ROLLS, PART NO. 90890-44372, CUTTING LENGTH 1.8M

\*1: A PRELEVER SUR BOBINE 50M, REFERENCE 90890-44372, LONGUEUR DE COUPE 1.8M

REF. NO.	PART NO. N° PIECES	DESCRIPTION DESCRIPTION	4	5	REMARKS REMARQUES
1	67D-15710-02	STARTER ASSY DEMARREUR COMPLET	1		
2	67D-15711-01	.CASE, STARTER .CARTER DE DEMARREUR	1		
3	63V-15795-01	.GUIDE, ROPE .GUIDE DE CABLE	1		
4	67D-15764-00	.COLLAR 1 .COLLERETTE 1	3		
5	67D-15714-00	.DRUM, SHEAVE .TAMBOUR, POULIE	1		
6	67D-15741-00	.PAWL, DRIVE .CLIQUET, ENTRAINEMENT	2		
7	67D-15713-00	.SPRING, STARTER .RESSORT DE DEMARREUR	1		
8	67D-15705-00	.SPRING, DRIVE PAWL .RESSORT DE CLIQUET	1		
9	67D-15767-00	.SPRING .RESSORT	2		
10	67D-15735-00	.GUIDE, CAM .COULISSEAU	1		
11	67D-15793-00	.SCREW .VIS	1		
12	63V-15764-00	.COLLAR 1 .COLLERETTE 1	1		
13	67D-15794-01	.STOPPER .BUTEE	1		
14	67D-15734-00	.SPRING, RETURN .RESSORT, RAPPEL	1		
15	*	.WIRE, STARTER (L:1800MM) .CABLE DE DEMARREUR (L:1800MM)	1		*1 *1
16	6G1-15755-00	.HANDLE, STARTER .POIGNEE, DE DEMARREUR	1		
17	6G1-15779-00	.COVER .COUVERCLE	1		
18	67D-15739-00	.WASHER, THRUST .RONDELLE, DE BUTEE	1		
19	67D-15744-00	.CIRCLIP .CIRCLIP	1		
20	67D-15762-00	SEAL, RUBBER 2 JOINT CAOUTCHOUC 2	1		
21	97095-06035	BOLT BOULON	2		
22	92995-06600	WASHER RONDELLE	2		
23	97095-06020	BOLT BOULON	1		
24	92995-06600	WASHER RONDELLE	1		
25	67D-15772-00	STAY 2 SUPPORT 2	1		
26	67D-15770-00	CABLE COMP., STARTER STOP CABLE, BUTEE DE DEMAR	1		
27	67D-42791-10	MARK 1 ETIQUETTE 1	1		

FIG. 10 STARTER

DEMARREUR

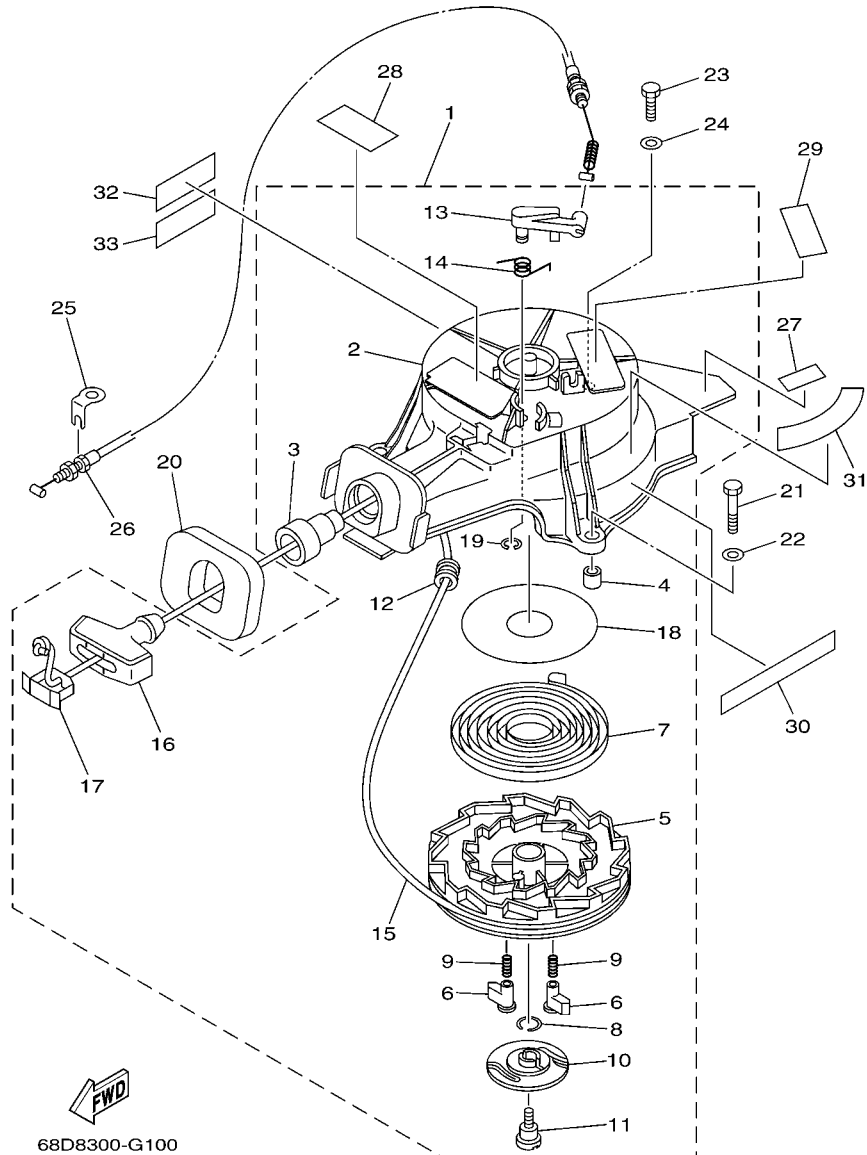

68D8300-G100

\*1: CUT FROM 50M ROLLS, PART NO. 90890-44372, CUTTING LENGTH 1.8M

\*1:A PRELEVER SUR BOBINE 50M ,REFERENCE 90890-44372, LONGUEUR DE COUPE 1.8M

REF. NO.	PART NO. N° PIECES	DESCRIPTION DESCRIPTION	4	5	REMARKS REMARQUES
28	6AH-81995-40	LABEL, WARNING ETIQUETTE, AVERTISSEMENT	1		
29	6AH-81995-50	LABEL, WARNING ETIQUETTE, AVERTISSEMENT	1		
30	68D-E3437-61	MARK, CAUTION MAKER	1		
31	68D-E4427-61	LABEL, INSTRUCTION ETIQUETTE, INSTRUCTION	1		
32	6AH-81994-40	LABEL, SAFETY ETIQUETTE, SECURITE	1		
33	6AH-81994-50	LABEL, SAFETY ETIQUETTE, SECURITE	1		

FIG. 11 GENERATOR

GENERATRICE

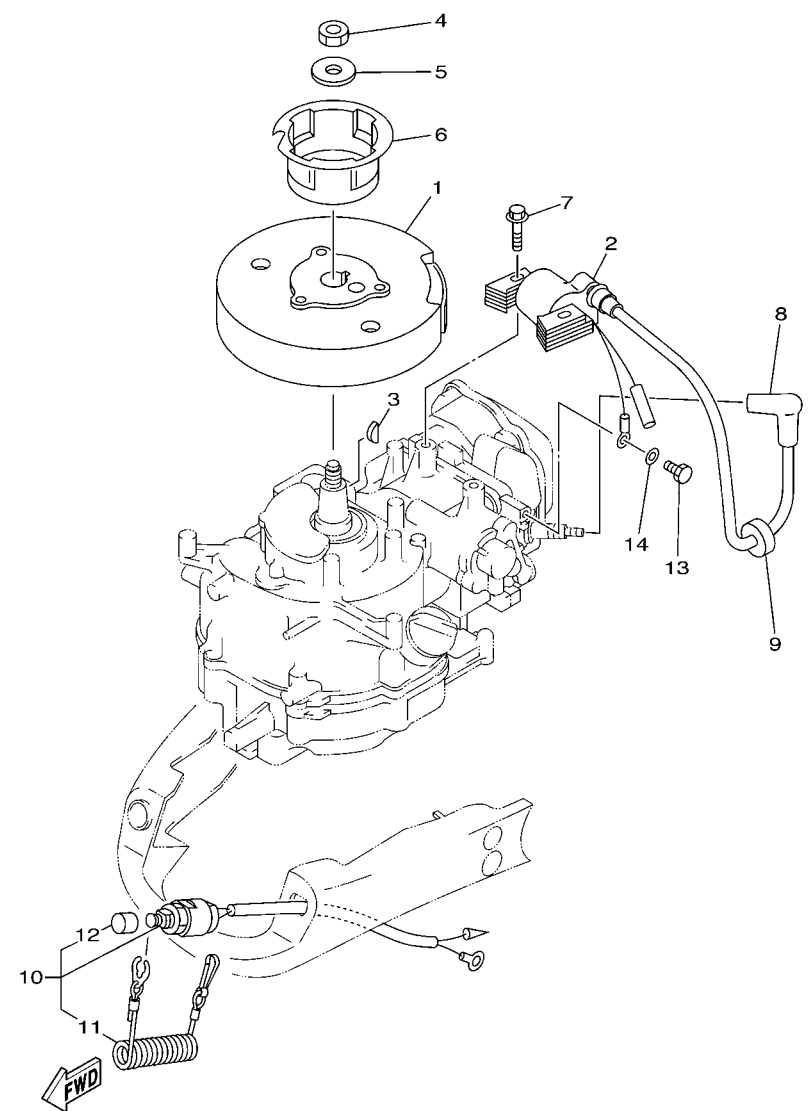

67D0300-8110

REF. NO.	PART NO. N° PIECES	DESCRIPTION DESCRIPTION	4 5				REMARKS REMARQUES
1	67D-85650-00	ROTOR ASSY ROTOR COMPLET	1				
2	67D-85640-00	T.C.I. UNIT ASSY ENS. BLOC T.C.I.	1				
3	90280-04M06	KEY, WOODRUFF CLAVETTE, DEMI-LUNE	1				
4	90170-10M33	NUT ECROU	1				
5	90201-105A2	WASHER, PLATE RONDELLE, PLATE	1				
6	67D-15723-00	PULLEY, STARTER POULIE DE DEMARREUR	1				
7	90105-06M24	BOLT, FLANGE BOULON	2				
8	6E3-82370-21	PLUG CAP ASSY ANTIPARASITE	1				
9	90480-25161	GROMMET PASSE-FIL	1				
10	67D-82575-00	ENGINE STOP SWITCH ASSY COUPE CIRCUIT CPLT	1				
11	682-82556-00	.LANYARD, STOP SWITCH .PLAQUETTE	1				
12	689-8257Y-00	.CAP .CHAPEAU	1				
13	97095-06012	BOLT BOULON	1				
14	92995-06600	WASHER RONDELLE	1				
-----							
-----							
-----							
-----							
-----							



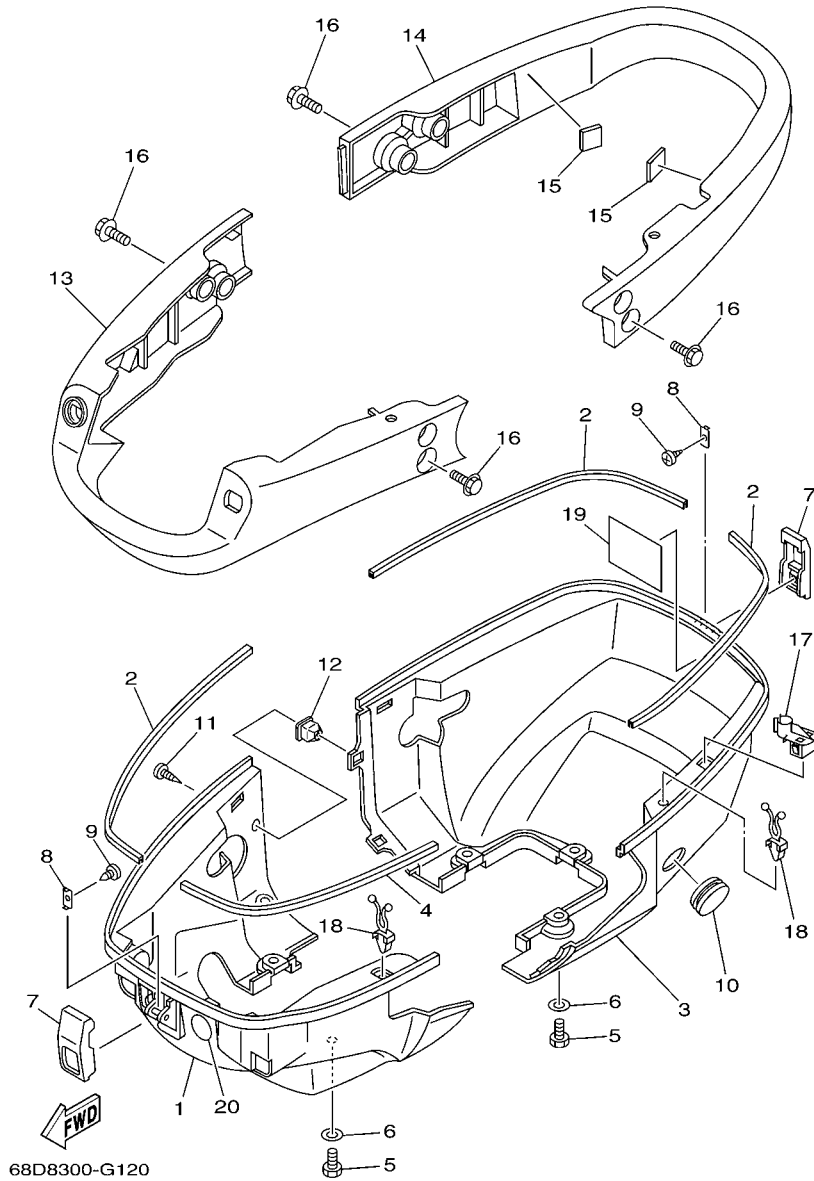
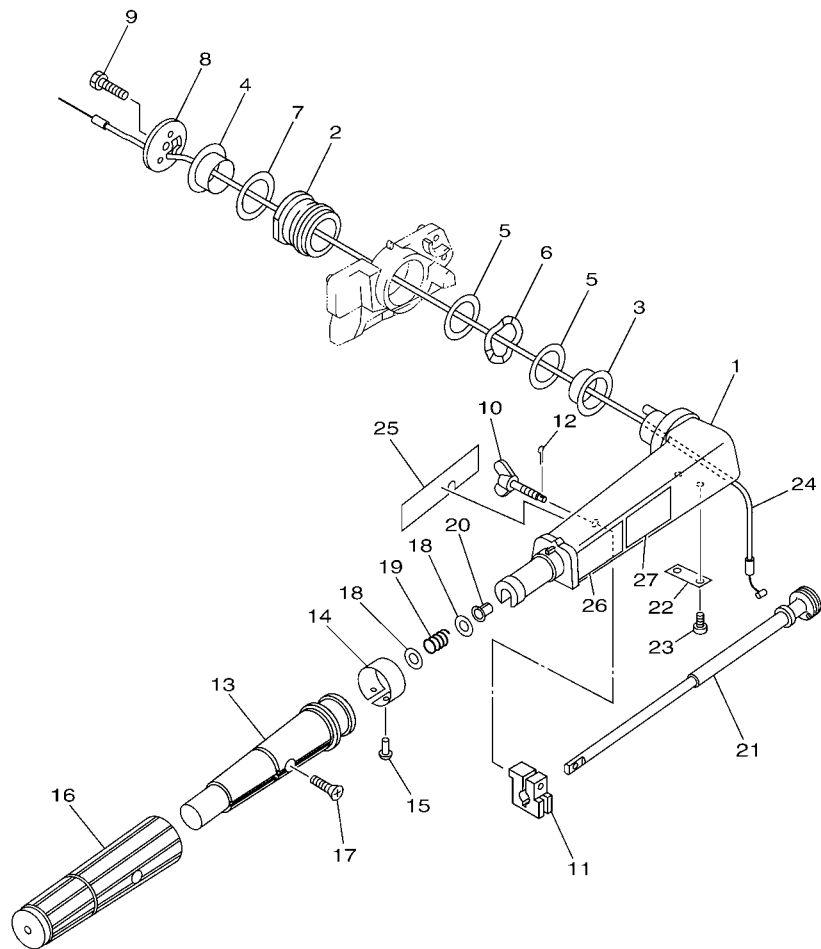

FIG. 12 BOTTOM COWLING

CAPOT INFERIEUR

REF. NO.	PART NO. N° PIECES	DESCRIPTION DESCRIPTION	4	5	6	7	8	REMARKS REMARQUES
1	68D-G2711-01	COWLING, BOTTOM 1 CUVETTE 1	1					
2	68D-G2628-00	SEAL JOINT	3					
3	68D-G2712-01	COWLING, BOTTOM 2 CUVETTE 2	1					
4	68D-G2629-00	SEAL JOINT	1					
5	97095-06016	BOLT BOULON	6					
6	92995-06600	WASHER RONDELLE	6					
7	6L5-42647-00	HOLDER, CLAMP BAND SUPPORT, SANDOW DE SERRAGE	2					
8	6L5-42823-00	PLATE, STOP PLAQUE	2					
9	90167-03M02	SCREW, TAPPING VIS, TETE FRAISEE	2					
10	90480-22M72	GROMMET PASSE-FIL	1					
11	90161-05001	SCREW, TAPPING VIS, TETE FRAISEE	3					
12	90480-10004	GROMMET PASSE-FIL	3					
13	68D-G2731-00	CARRYING HANDLE POIGNEE DE PORTAGE	1					
14	68D-G2735-00	PROTECTOR PROTECTEUR	1					
15	67D-42662-00	DAMPER AMORTISSEUR	2					
16	90119-06M79	BOLT, WITH WASHER BOULON, AVEC RONDELLE	8					
17	90464-07M50	CLAMP BRIDE	1					
18	90464-07078	CLAMP BRIDE	2					
19	68D-E2138-60	MARK, CAUTION MAKER	1					
20	60R-F415E-00	LABEL, CAUTION ETIQUETTE, RECOMMANDATION	1					



  
 68D8100-G130

FIG. 13 STEERING

DIRECTION

REF. NO.	PART NO. N° PIECES	DESCRIPTION DESCRIPTION	4 5				REMARKS REMARQUES
1	68D-G2111-00-4D	HANDLE, STEERING POIGNEE	1				
2	67D-42129-00	BUSHING, RUBBER DOUILLE, CAOUTCHOUC	1				
3	68D-G2171-00	BUSHING COUSSINET	1				
4	68D-G2172-00	BUSHING 2 DOUILLE 2	1				
5	68D-G2181-00	WASHER RONDELLE	2				
6	69M-G2188-00	WASHER, WAVE RONDELLE, ONDULEE	1				
7	68D-G2182-00	WASHER 2 RONDELLE 2	1				
8	68D-G2131-01	COVER, HANDLE STEERING COUVERCLE	1				
9	97075-08025	BOLT BOULON	1				
10	6G1-42125-01	BOLT, FRICTION ADJUSTING BOULON	1				
11	6G1-42126-00	FRICTION, STEERING HANDLE GRIP CUVETTE, POIGNEE DE DIRECTION	1				
12	91490-16010	PIN, COTTER GOUPILLE	1				
13	68D-G2119-00	GRIP, STEERING HANDLE POIGNEE, BARRE FRANCHE	1				
14	68D-G2137-00	INDICATOR, THROTTLE INDICATEUR, ACCELERATION	1				
15	90269-02M09	RIVET RIVET	1				
16	68D-G2177-10	RUBBER, HANDLE CAOUTCHOUC, POIGNEE	1				
17	90149-05M13	SCREW VIS	1				
18	90201-10M02	WASHER, PLATE RONDELLE, PLATE	2				
19	90501-23215	SPRING, COMPRESSION RESSORT, COMPRESSION	1				
20	90386-08032	BUSH DOUILLE	1				
21	6G1-42138-01	LEVER, THROTTLE LEVIER, ACCELERATEUR	1				
22	68D-G2159-00	STAY SUPPORT	1				
23	97885-05012	SCREW, PAN HEAD VIS, A ENCOCHE	2				
24	68D-F6301-00	THROTTLE CABLE ASSY CABLE D'ACCELERATEUR	1				
25	68D-E571Y-60	MARK, CAUTION MAKER	1				
26	6AH-42794-40	LABEL, WARNING (GENERAL) ETIQUETTE, AVERTISSEMENT	1				
27	6AH-42794-50	LABEL, WARNING (GENERAL) ETIQUETTE, AVERTISSEMENT	1				

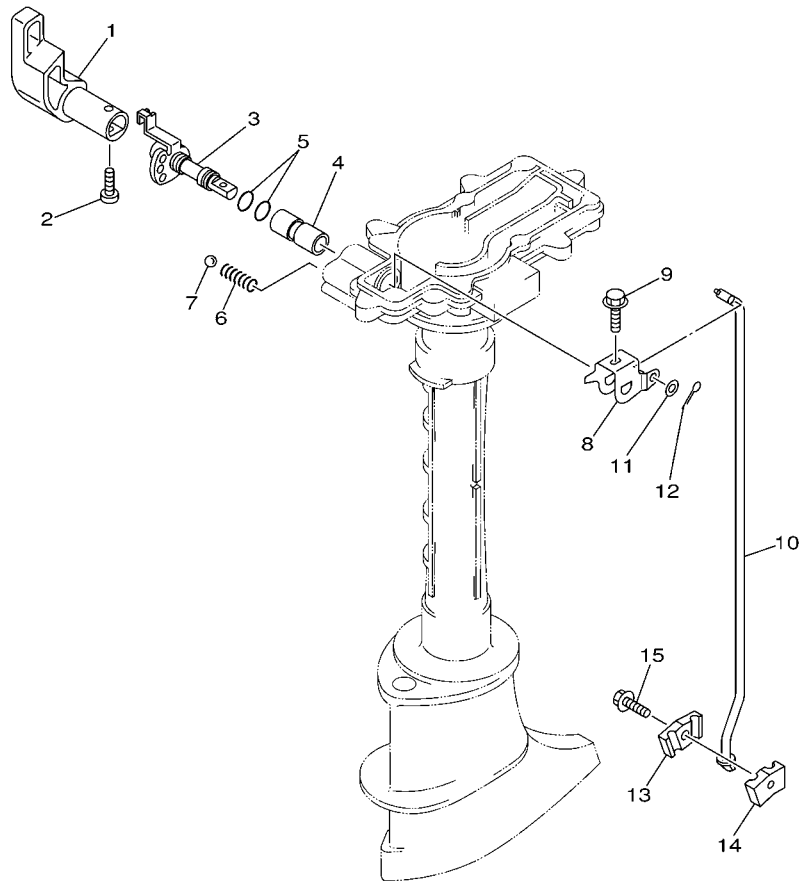

67D0010-0141

FIG. 14 CONTROL

COMMANDE

REF. NO.	PART NO. N° PIECES	DESCRIPTION DESCRIPTION	4	5	REMARKS REMARQUES
1	68D-G4111-00	HANDLE, GEAR SHIFT POIGNEE, LEVIER D'EMBRAYAGE	1		
2	98680-05520	SCREW, OVAL HEAD VIS, TETE FRAISEE BOMBEE	1		
3	68D-G4119-00	SHAFT, CHANGE ARBRE, SELECTION	1		
4	68D-G4122-01	BUSHING, SHIFT ROD LEVER DOUILLE, LEVIER D'EMBRAYAGE	1		
5	93210-09350	O-RING JOINT TORIQUE	2		
6	90501-12802	SPRING, COMPRESSION RESSORT, COMPRESSION	1		
7	93505-16024	BALL BILLE	1		
8	68D-G4121-00	LEVER, SHIFT ROD LEVIER, TIGE D'INVERSION	1		
9	90119-05M04	BOLT, WITH WASHER BOULON, AVEC RONDELLE	1		
10	67D-44143-01	ROD, SHIFT TIGE D'EMBRAYAGE	1		
11	92990-05600	WASHER, PLATE RONDELLE, PLATE	1		
12	91490-16010	PIN, COTTER GOUPILLE	1		
13	68D-G4145-00	CONNECTOR, SHIFT ROD CONNECTEUR, TIGE D'INVERSION	1		
14	68D-G4146-00	CONNECTOR, SHIFT ROD CONNECTEUR, TIGE D'INVERSION	1		
15	90119-06ME0	BOLT, WITH WASHER BOULON, AVEC RONDELLE	1		

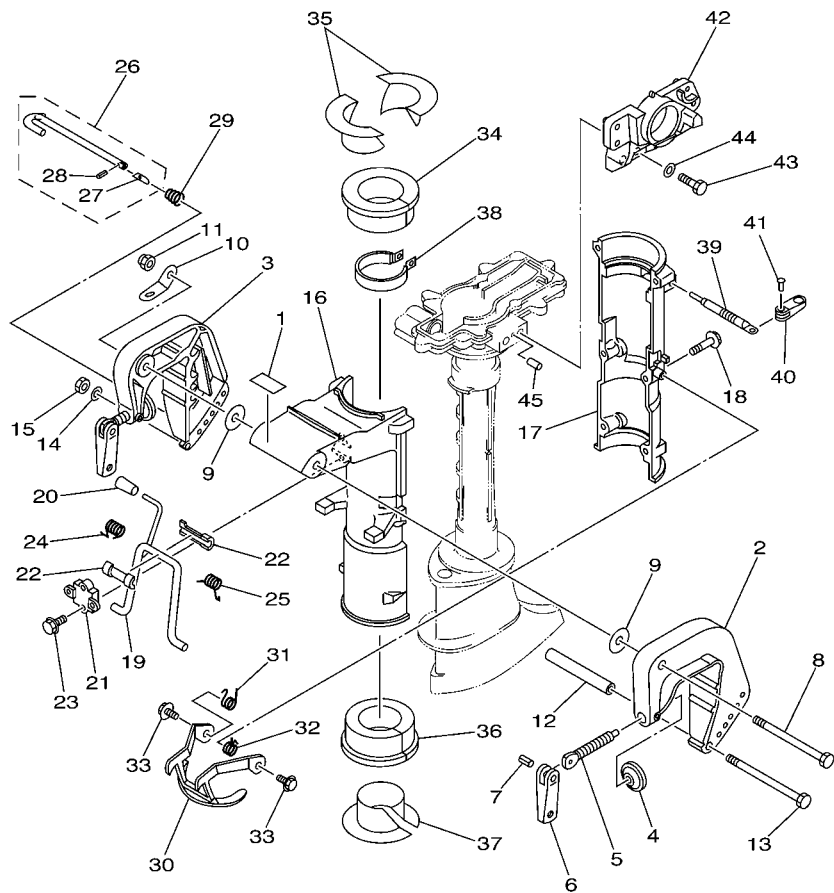

**FWD**  
68D5110-D150

**FIG. 15 BRACKET**

**SUPPORT**

REF. NO.	PART NO. N° PIECES	DESCRIPTION DESCRIPTION	4/5				REMARKS REMARQUES
1	68D-F4591-00	EMBLEM, FUEL COCK ADHESIF	1				
2	6L8-G3111-01-4D	BRACKET, CLAMP 1 PRESSE 1	1				
3	6L8-G3112-00-4D	BRACKET, CLAMP 2 PRESSE 2	1				
4	620-43114-00	PAD, TRANSOM CLAMP RONDELLE D'APPUI	2				
5	6E0-43116-01	SCREW, TRANSOM CLAMP VIS DE PRESSE	2				
6	6L8-G3118-01	HANDLE, TRANSOM CLAMP POIGNEE DE VIS DE PRESSE	2				
7	90243-04M01	PIN GOUILLE	2				
8	90101-08M07	BOLT BOULON	1				
9	90202-08M58	WASHER, PLATE RONDELLE, PLATE	2				
10	68D-G3113-00	PLATE, CLAMP BRACKET PLAQUETTE, PRESSE	1				
11	90185-08057	NUT, SELF-LOCKING ECROU, AUTO-BLOQUANT	1				
12	90387-06M11	COLLAR COLLERETTE	1				
13	90101-06335	BOLT BOULON	1				
14	92990-06600	WASHER, PLATE RONDELLE, PLATE	1				
15	95380-06600	NUT, HEXAGON ECROU	1				
16	68D-G3311-00-4D	BRACKET, SWIVEL 1 SUPPORT, PIVOT 1	1				
17	68D-G3312-00-4D	BRACKET, SWIVEL 2 SUPPORT, PIVOT 2	1				
18	95895-06035	BOLT, FLANGE BOULON	6				
19	6E0-43181-00	LEVER, TILT STOP LEVIER, VERROUILLAGE RELEVAGE	1				
20	6E0-43632-00	KNOB, TILT POIGNEE, LEVIER DE RELEVAGE	1				
21	6E0-43313-00-4D	BRACKET, SWIVEL 3 SUPPORT, PIVOT 3	1				
22	620-43189-00	BUSHING COUSSINET	2				
23	95895-06020	BOLT, FLANGE BOULON	2				
24	90508-16020	SPRING, TORSION RESSORT, TORSION	1				
25	90508-16021	SPRING, TORSION RESSORT, TORSION	1				
26	68D-G3160-00	TILT ROD ASSY BROCHE D'INCLINAISON (ENS.)	1				
27	6N0-G3165-00	PLATE, TILT LOCK TAQUET, BROCHE INCLINAISON	1				

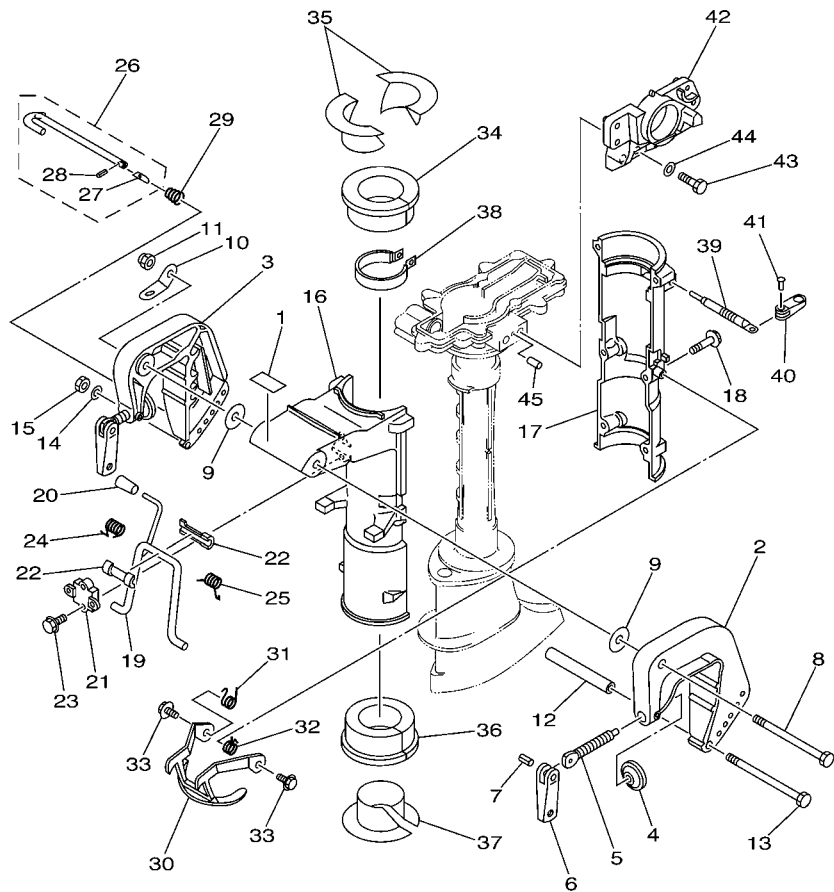

FWD  
68D5110-D150

FIG. 15 BRACKET

SUPPORT

REF. NO.	PART NO. N° PIECES	DESCRIPTION DESCRIPTION	4 5				REMARKS REMARQUES
28	91690-30008	.PIN, SPRING .AGRAFFE	1				
29	90502-08M05	SPRING, CONICAL RESSORT, CONIQUE	1				
30	6E0-43614-00-5B	PLATE, TILT LOCK ETRIER, VERROUILLAGE MARCHE AR	1				
31	90508-14M10	SPRING, TORSION RESSORT, TORSION	1				
32	90508-14M11	SPRING, TORSION RESSORT, TORSION	1				
33	95895-06010	BOLT, FLANGE BOULON	2				
34	68D-G2537-00	BUSHING, PIVOT SHAFT COUSSINET	1				
35	68D-G2539-00	BUSHING, PIVOT SHAFT COUSSINET	2				
36	68D-G2538-00	BUSHING, PIVOT SHAFT COUSSINET	1				
37	68D-G2549-00	BUSHING, PIVOT SHAFT COUSSINET	1				
38	6E0-42528-03	PLATE, FRICTION PLAQUE, FRICTION	1				
39	6L5-42529-01	SCREW, FRICTION PIECE VIS, PIECE DE FRICTION	1				
40	68D-G2561-01	KNOB, STEERING LOCK BOUTON	1				
41	90266-04M05	RIVET RIVET	1				
42	68D-G2511-00-4D	BRACKET, STEERING CADRE, DIRECTION	1				
43	97075-08030	BOLT BOULON	2				
44	92995-08600	WASHER RONDELLE	2				
45	93604-12M07	PIN, DOWEL CLAVETTE	1				

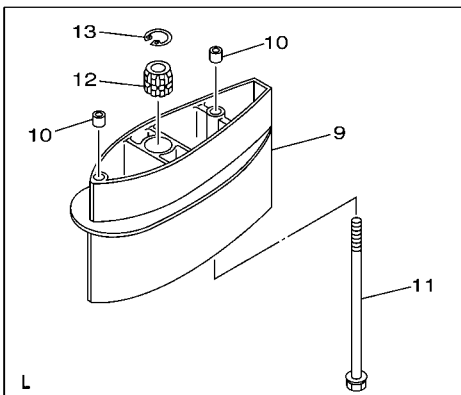
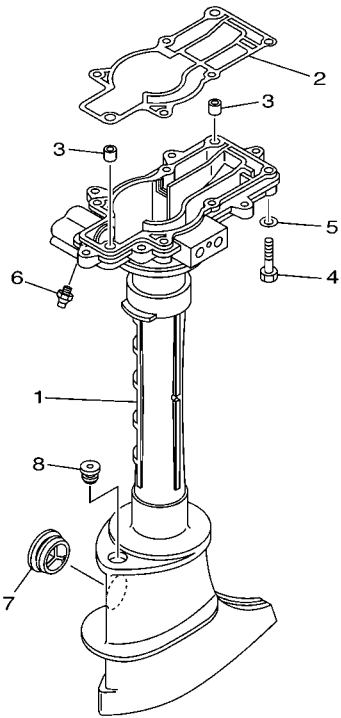

68D2010-2160

FIG. 16 UPPER CASING

FOURREAU

REF. NO.	PART NO. N° PIECES	DESCRIPTION DESCRIPTION	4	5	6	7	8	REMARKS REMARQUES
1	68D-G5111-01-4D	CASING, UPPER FOURREAU	1					
2	67D-45113-A0	GASKET, UPPER CASING JOINT, TUBE D'ARBRE	1					
3	90387-06806	COLLAR COLLERETTE	2					
4	97095-06035	BOLT BOULON	7					
5	92995-06600	WASHER RONDELLE	7					
6	93700-06M03	NIPPLE, GREASE PION	1					
7	647-45151-01	COVER, UPPER CASING CAPUCHON, FOURREAU	1					
8	90480-10M13	GROMMET PASSE-FIL	1					
9	68D-G5211-00-4D	EXTENSION EXTENSION	1					L(22.1")
10	90387-06806	COLLAR COLLERETTE	2					L(22.1")
11	90119-06M77	BOLT, WITH WASHER BOULON, AVEC RONDELLE	2					L(22.1")
12	6E0-45318-01	BUSHING, DRIVE SHAFT DOUILLE, ARBRE MOTEUR	1					L(22.1")
13	93420-22M03	CIRCLIP CIRCLIP, TYPE S	1					L(22.1")

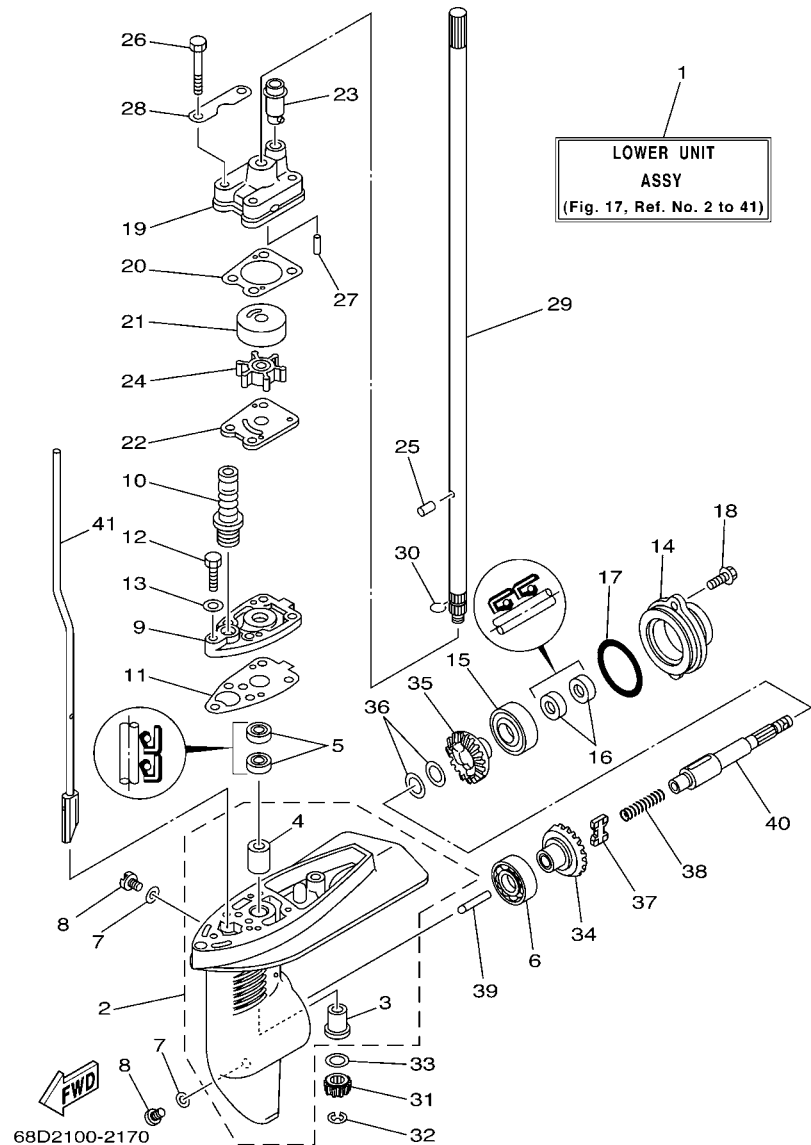

68D2100-2170

FIG. 17 LOWER CASING & DRIVE 1

BOITIER D'HELICE TRANSMISSION1

REF. NO.	PART NO. N° PIECES	DESCRIPTION DESCRIPTION	4	5	REMARKS REMARQUES
1	68D-G5300-01-4D	LOWER UNIT ASSY UNITE INFERIEURE (ENS.)	1		S(17.1") S(17.1")
	68D-G5300-11-4D	LOWER UNIT ASSY UNITE INFERIEURE (ENS.)	1		L(22.1") L(22.1")
2	68D-G5311-00-4D	CASING, LOWER BOITIER D'HELICE	1		
3	6E0-45317-09	.BUSHING, DRIVE SHAFT .DOUILLE, ARBRE MOTEUR	1		
4	6E0-45316-09	.BUSHING, DRIVE SHAFT .DOUILLE, ARBRE MOTEUR	1		
5	93101-10M14	OIL SEAL JOINT SPY	2		
6	93306-004YH	BEARING ROULEMENT	1		
7	90430-08020	GASKET JOINT	3		
8	90340-08002	PLUG, STRAIGHT SCREW PLOT, FILETE DROIT	3		
9	68D-G5321-00	PLATE PLAQUETTE	1		
10	6L2-44147-00	BOOT, SHIFT ROD SOUFFLET, TIGE D'INVERSION	1		
11	68D-G5315-A0	PACKING, LOWER CASING JOINT, BOITIER D'HELICE	1		
12	97095-06025	BOLT BOULON	1		
13	92995-06600	WASHER RONDELLE	1		
14	68D-G5361-00-4D	CAP, LOWER CASING COUVERCLE, BOITIER D'HELICE	1		
15	93306-004YH	BEARING ROULEMENT	1		
16	93101-13M12	OIL SEAL JOINT SPY	2		
17	93210-48214	O-RING JOINT TORIQUE	1		
18	95895-06016	BOLT, FLANGE BOULON	2		
19	68D-G4311-01	HOUSING, WATER PUMP CORPS, POMPE A EAU	1		
20	68D-G4315-A0	GASKET, WATER PUMP JOINT, POMPE A EAU	1		
21	6E0-44322-02	INSERT, CARTRIDGE CUVETTE	1		
22	6E0-44323-00	OUTER PLATE, CARTRIDGE PLAQUE EXTERIEURE	1		
23	67D-44366-00	DAMPER, WATER SEAL JOINT, TUBE D'EAU	1		
24	6E0-44352-00	IMPELLER TURBINE	1		
25	93604-09066	PIN, DOWEL CLAVETTE	1		
26	97095-06045	BOLT BOULON	4		

FIG. 17 LOWER CASING & DRIVE 1

BOITIER D'HELICE TRANSMISSION1

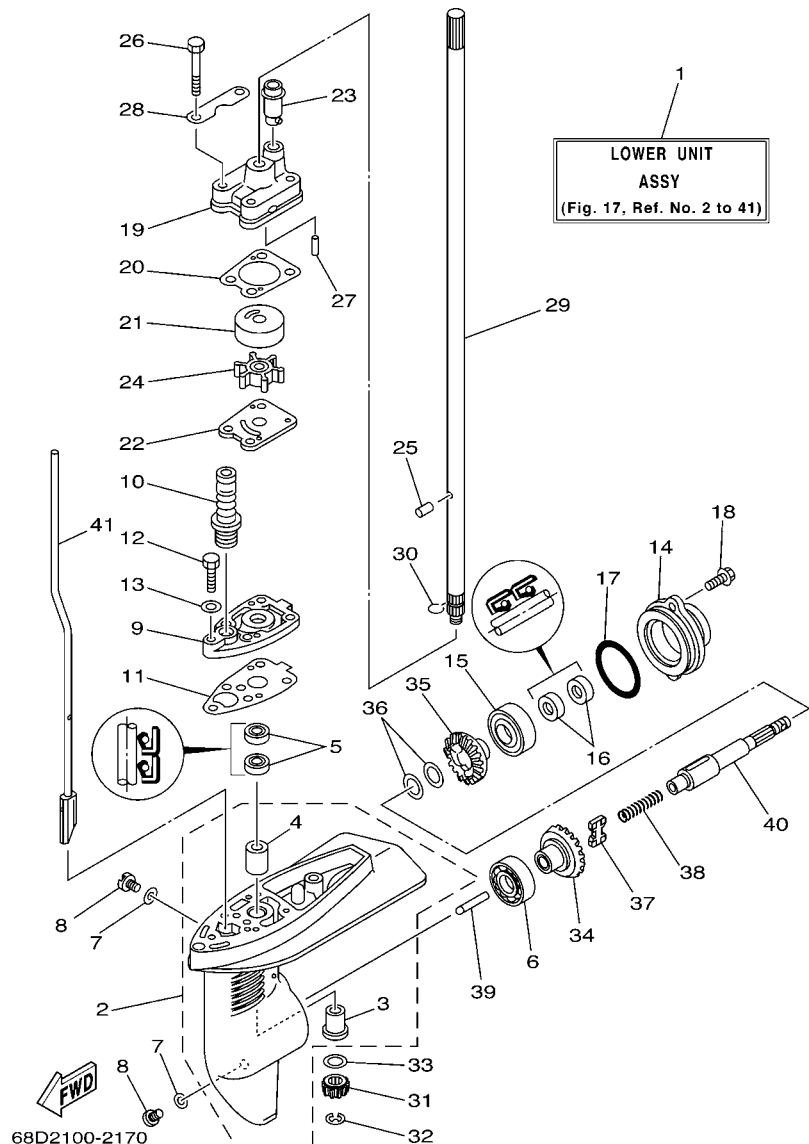

REF. NO.	PART NO. N° PIECES	DESCRIPTION DESCRIPTION	QTY				REMARKS REMARQUES
27	93604-18080	PIN, DOWEL CLAVETTE	2				
28	68D-G4328-00	PLATE PLAQUETTE	2				
29	68D-G5511-00	SHAFT, DRIVE ARBRE, MOTEUR	1				S(17.1") S(17.1")
	68D-G5511-10	SHAFT, DRIVE ARBRE, MOTEUR	1				L(22.1") L(22.1")
30	90467-08M01	CLIP JONC	1				
31	6E0-45551-00	PINION (13T) PIGNON D'ATTAQUE (13D)	1				
32	99001-06600	CIRCLIP CIRCLIP	1				
33	90201-11M49	WASHER, PLATE RONDELLE, PLATE	1				
34	67D-45560-00	GEAR 1 (27T) PIGNON 1 (27T)	1				
35	67D-45570-00	GEAR 2 (27T) PIGNON 2 (27T)	1				
36	67D-45576-00	WASHER, THRUST RONDELLE DE CALAGE	2				
37	67D-45631-01	CLUTCH, DOG CRABOT	1				
38	90501-10064	SPRING, COMPRESSION RESSORT, COMPRESSION	1				
39	67D-45635-00	PLUNGER, SHIFT POUSSOIR D'EMBAYAGE	1				
40	68D-G5611-10	SHAFT, PROPELLER ARBRE, HELICE	1				
41	68D-G4150-00	SHIFT CAM ASSY CAME D'INVERSION	1				S(17.1") S(17.1")
	68D-G4150-10	SHIFT CAM ASSY CAME D'INVERSION	1				L(22.1") L(22.1")



FIG. 18 LOWER CASING & DRIVE 2

BOITIER D'HELICE TRANSMISSION2

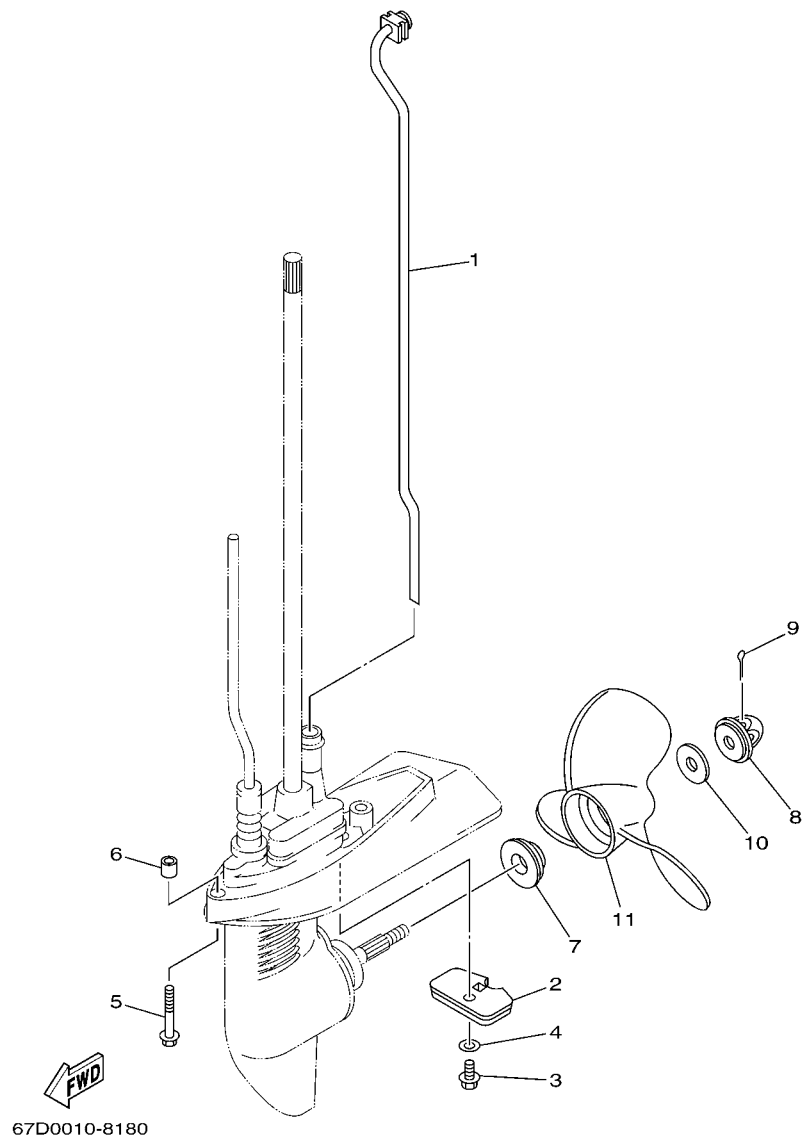

REF. NO.	PART NO. N° PIECES	DESCRIPTION DESCRIPTION	4 5				REMARKS REMARQUES
1	68D-G4360-00	WATER TUBE ASSY TUYAU,EAU	1				S(17.1") S(17.1")
	68D-G4360-10	WATER TUBE ASSY TUYAU,EAU	1				L(22.1") L(22.1")
2	68D-G5251-00	ANODE ANODE	1				
3	95895-06012	BOLT, FLANGE BOULON	1				
4	92990-06300	WASHER, INTERNAL TOOTH RONDELLE, DENTURE INTERNE	1				
5	90119-06M40	BOLT, WITH WASHER BOULON, AVEC RONDELLE	2				S(17.1") S(17.1")
6	90387-06806	COLLAR COLLERETTE	2				
7	68D-G5987-00	SPACER ENTRETOISE	1				
8	6L5-45616-00	NUT, PROPELLER CONE, HELICE	1				
9	91490-25030	PIN, COTTER GOUPILLE	1				
10	90201-08M54	WASHER, PLATE RONDELLE, PLATE	1				
11	6E0-45941-01-EL	PROPELLER (3X7-1/2"X8"-BA) HELICE (3X7-1/2"X8"-BA)	1				UR UR
	6E0-45943-01-EL	PROPELLER (3X7-1/2"X7"-BA) HELICE (3X7-1/2"X7"-BA)	1				UR UR
	6E0-45949-00-EL	PROPELLER (3X7-1/4"X6-1/2"-BA) HELICE (3X7-1/4"X6-1/2"-BA)	1				UR UR

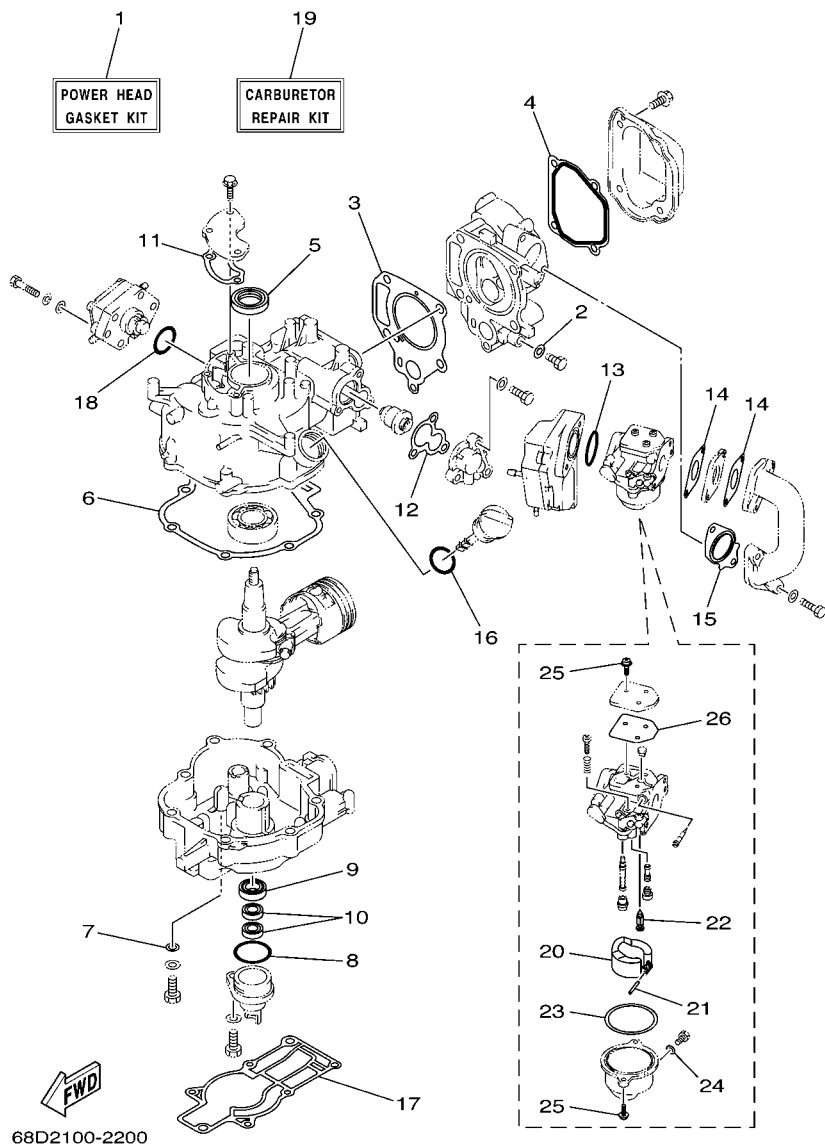

FIG. 19 REPAIR KIT 1

KITS DE REPARATION 1

REF. NO.	PART NO. N° PIECES	DESCRIPTION DESCRIPTION	45				REMARKS REMARQUES
1	68D-WE001-01	POWER HEAD GASKET KIT POCHETTE DE JINTS TETE MOTRICE	1				
2	90430-08800	.GASKET .JOINT	1				
3	67D-11181-A0	.GASKET, CYLINDER HEAD 1 .JOINT, DE CULASSE 1	1				
4	68D-E1193-A0	.GASKET, HEAD COVER 1 .JOINT, COUVERCLE DE CULASSE 1	1				
5	93102-25090	.OIL SEAL .JOINT SPY	1				
6	68D-11351-A0	.GASKET, CYLINDER .JOINT, D'EMBASE	1				
7	90201-08818	.WASHER, PLATE .RONDELLE, PLATE	1				
8	93210-35537	.O-RING .JOINT TORIQUE	1				
9	93102-20108	.OIL SEAL .JOINT SPY	1				
10	93102-10004	.OIL SEAL .JOINT SPY	2				
11	68D-E1169-A0	.GASKET, BREATHER COVER .JOINT, COUVERCLE DE RENIFLARD	1				
12	68D-E2414-A0	.GASKET, COVER .JOINT, COUVERCLE	1				
13	93210-31MJ5	.O-RING .JOINT TORIQUE	1				
14	68D-E3646-A0	.GASKET, MANIFOLD 2 .JOINT, TUBULURE 2	2				
15	68D-E3645-A0	.GASKET, MANIFOLD 1 .JOINT, TUBULURE 1	1				
16	93210-24M79	.O-RING .JOINT TORIQUE	1				
17	67D-45113-A0	.GASKET, UPPER CASING .JOINT, TUBE D'ARBRE	1				
18	93210-27ME3	.O-RING .JOINT TORIQUE	1				
19	67D-W0093-01	CARBURETOR REPAIR KIT KIT DE REPARATION CARBURATEUR	1				
20	68T-14385-00	.FLOAT .FLOTTEUR	1				
21	67D-14386-00	.PIN, FLOAT .AXE, FLOTTEUR	1				
22	67D-14546-00	.VALVE, NEEDLE .POINTEAU	1				
23	67D-14984-00	.GASKET, FLOAT CHAMBER .JOINT, CUVE DE FLOTTEUR	1				
24	6J8-14959-00	.GASKET .JOINT	1				
25	97980-04112	.SCREW, WITH WASHER .VIS, AVEC RONDELLE	2				
26	67D-14536-00	.GASKET .JOINT	1				

KITS DE REPARATION 2

FIG. 20 REPAIR KIT 2

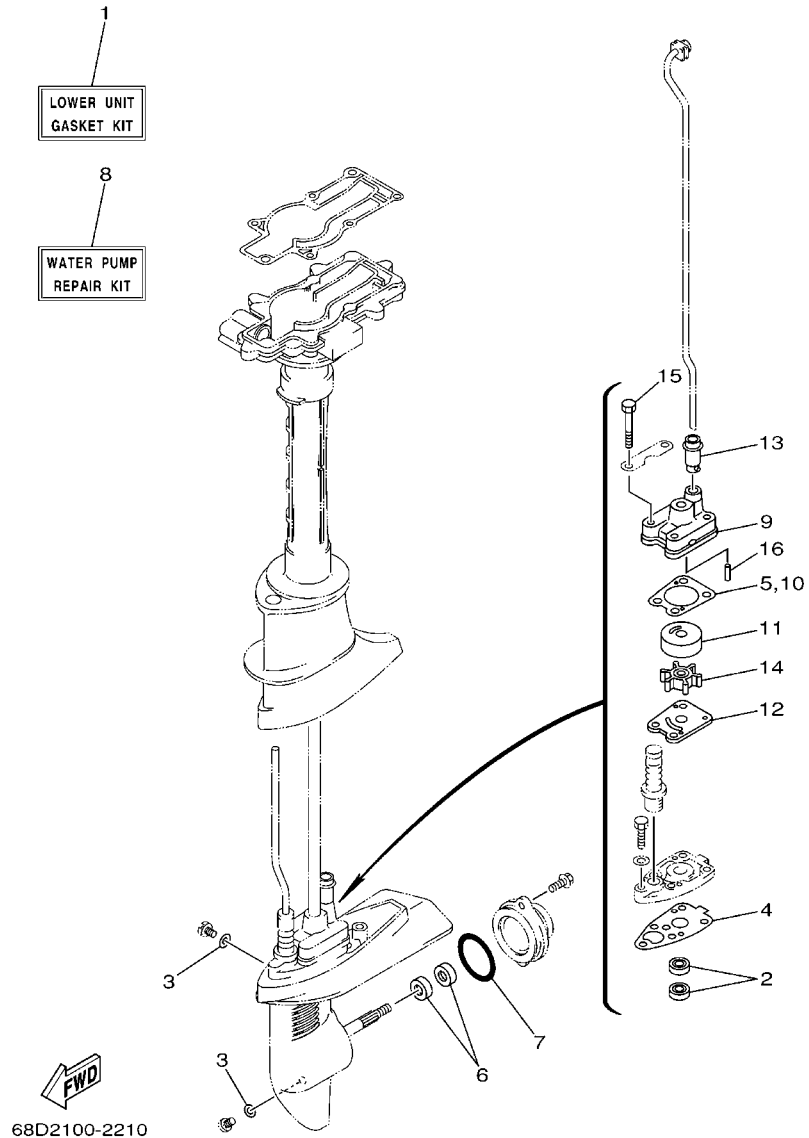

REF. NO.	PART NO. N° PIECES	DESCRIPTION DESCRIPTION	4 5				REMARKS REMARQUES
1	6E0-W0001-C1	LOWER UNIT GASKET KIT POCHETTE DE JOINTS EMBASE	1				
2	93101-10M14	.OIL SEAL .JOINT SPY	2				
3	90430-08020	.GASKET .JOINT	3				
4	68D-G5315-A0	.PACKING, LOWER CASING .JOINT, BOITIER D'HELICE	1				
5	68D-G4315-A0	.GASKET, WATER PUMP .JOINT, POMPE A EAU	1				
6	93101-13M12	.OIL SEAL .JOINT SPY	2				
7	93210-48214	.O-RING .JOINT TORIQUE	1				
8	68D-WG078-00	WATER PUMP REPAIR KIT KIT DE REPARATION DE LA POMPE	1				
9	68D-G4311-01	.HOUSING, WATER PUMP .CORPS, POMPE A EAU	1				
10	68D-G4315-A0	.GASKET, WATER PUMP .JOINT, POMPE A EAU	1				
11	6E0-44322-02	.INSERT, CARTRIDGE .CUVETTE	1				
12	6E0-44323-00	.OUTER PLATE, CARTRIDGE .PLAQUE EXTERIEURE	1				
13	67D-44366-00	.DAMPER, WATER SEAL .JOINT, TUBE D'EAU	1				
14	6E0-44352-00	.IMPELLER .TURBINE	1				
15	97095-06045	.BOLT .BOULON	4				
16	93604-18080	.PIN, DOWEL .CLAVETTE	2				